

RPS Pipe Supports



Engineered Composite Solutions



Pipe Supports

Table of Contents

General Notes	Page 5
Pictorial Index	
Pipe Supports.....	Page 7
Duct Supports	Page 12
Pipe Supports	
Figure S1: U-Strap W/ Shield (1" – 12" Diameter)	Page 14
Figure S2: U-Bolt W/ Shield (1" – 12" Diameter)	Page 15
Figure S4: Clevis Hanger (1" – 18" Diameter)	Page 16
Figure S5: Wide Clamp Hanger (1" – 18" Diameter)	Page 17
Figure S5: Wide Clamp Hanger (20" – 60" Diameter).....	Page 18
Figure S7: FRP Wear Pad (1" – 12" Diameter)	Page 19
Figure S8: Slide Shield (1" – 12" Diameter)	Page 20
Figure S9: Pipe Cradle (1" – 10" Diameter)	Page 21
Figure S9B: Pipe Cradle (12" – 60" Diameter).....	Page 22
Figure S10: Pipe Stand - Fixed Height (1" – 8" Diameter).....	Page 23
Figure S11: Pipe Stand - Adjustable Height (1" – 8" Diameter).....	Page 24
Figure S12: Flange Slide (1" – 10" Diameter).....	Page 25
Figure S12B: Flange Slide (12" – 30" Diameter).....	Page 26
Figure S12B: Flange Slide (36" – 60" Diameter).....	Page 27
Figure S13: Flange Guide (1" – 10" Diameter)	Page 28
Figure S13B: Flange Guide (12" – 30" Diameter)	Page 29
Figure S13B: Flange Guide (36" – 60" Diameter)	Page 30
Figure S14: Flange Anchor (1" – 30" Diameter)	Page 31
Figure S14: Flange Anchor (36" – 60" Diameter)	Page 32
Figure S15: Flange Linestop (1" – 10" Diameter)	Page 33
Figure S15B: Flange Linestop (12" – 30" Diameter).....	Page 34
Figure S15B: Flange Linestop (36" – 60" Diameter).....	Page 35
Figure S16: Flange Hanger (1" – 18" Diameter)	Page 36
Figure S17: Flange Riser Guide (12" – 30" Diameter).....	Page 37
Figure S17: Flange Riser Guide (36" – 60" Diameter).....	Page 38
Figure S18: Flange Riser Support (12" – 60" Diameter)	Page 39

Pipe Supports

Figure S19: Flange Riser Support W/ Guides (12" – 60" Diameter)	Page 40
Figure P7: Elbow Support Slide Plate (2" – 10" Diameter).....	Page 41
Figure P7B: Elbow Support Slide Plate (12" – 24" Diameter).....	Page 42
Figure P8: Base Slide (1" – 10" Diameter)	Page 43
Figure P8L: Base Slide – Low Profile (1" – 10" Diameter).....	Page 44
Figure P9: Base Guide (1" – 10" Diameter).....	Page 45
Figure P9L: Base Guide – Low Profile (1" – 10" Diameter).....	Page 46
Figure P10: Base Anchor (1" – 10" Diameter)	Page 47
Figure P10L: Base Anchor – Low Profile (1" – 10" Diameter)	Page 48
Figure P13: Riser Guide (1" – 20" Diameter).....	Page 49
Figure P13: Riser Guide (24" - 60" Diameter).....	Page 50
Figure P14: Riser Support (1" - 10" Diameter).....	Page 51
Figure P14: Riser Support (12" - 30" Diameter).....	Page 52
Figure P14: Riser Support (36" - 60" Diameter)	Page 53
Figure P15: Double Rod Riser Hanger (1" - 10" Diameter).....	Page 54
Figure P15: Double Rod Riser Hanger (12" – 30" Diameter).....	Page 55
Figure P16: Riser Support W/ Guides (1" – 10" Diameter)	Page 56
Figure P16: Riser Support W/ Guides (12" – 30" Diameter)	Page 57
Figure P16: Riser Support W/ Guides (36" – 60" Diameter)	Page 58
Figure P17: Base Linestop (12" – 30" Diameter).....	Page 59
Figure P17: Base Linestop (36" – 60" Diameter).....	Page 60
Figure P18: Base Slide (12" – 30" Diameter).....	Page 61
Figure P18: Base Slide (36" – 60" Diameter)	Page 62
Figure P19: Base Guide (12" – 30" Diameter)	Page 63
Figure P19: Base Guide (36" – 60" Diameter).....	Page 64
Figure P20: Base Anchor (12" – 30" Diameter).....	Page 65
Figure P20: Base Anchor (36" – 60" Diameter).....	Page 66
Figure XL12: Extra Large Slide (66" – 108" Diameter).....	Page 67
Figure XL13: Extra Large Guide (66" – 108" Diameter)	Page 68
Figure XL14: Extra Large Anchor (66" – 108" Diameter)	Page 69

Pipe Supports

Duct Supports

Figure D1: Duct Clamp Hanger (20" – 60" Diameter).....	Page 70
Figure D3: Duct Cradle Base Slide (20" – 60" Diameter)	Page 71
Figure D4: Duct Base Linestop (20" – 36" Diameter)	Page 72
Figure D4: Duct Base Linestop (42" – 60" Diameter)	Page 73
Figure D5: Duct Base Slide (20" – 36" Diameter)	Page 74
Figure D5: Duct Base Slide (42" – 60" Diameter)	Page 75
Figure D6: Duct Base Guide (20" – 36" Diameter)	Page 76
Figure D6: Duct Base Guide (42" – 60" Diameter)	Page 77
Figure D7: Duct Base Anchor (20" – 36" Diameter).....	Page 78
Figure D7: Duct Base Anchor (42" – 60" Diameter)	Page 79
Figure D16: Duct Riser Guide (20" – 30" Diameter)	Page 80
Figure D16: Duct Riser Guide (36" – 60" Diameter)	Page 81
Figure D17: Duct Riser Support W/ Guides (20" – 30" Diameter).....	Page 82
Figure D17: Duct Riser Support W/ Guides (36" – 60" Diameter).....	Page 83
Support Options	
Figure 01: Variable Spring Hanger Supports.....	Page 84
Figure 02: Slide Bearings.....	Page 85
Figure 03: Base Plates	Page 86
Figure 04: Guide Clips	Page 87
Figure 05: Expansion Joint W/ Control Rods.....	Page 88
Painting Specification	Page 89

Pipe Support General Notes

- 1) The following catalog support configurations are designed for the listed allowable loads. If actual load requirements differ from the defined allowable loads, configurations and materials can be altered to accommodate the load requirements. The defined vertical loads are downward in direction unless otherwise noted. Please specify all load requirements with placement of order.
 - 2) The defined support loads and designs are based on typical FRP and plastic pipe/duct system arrangements, design parameters and spans between supports. Support designs and configurations can be altered to accommodate specific project needs.
 - 3) Allowable loads for pipe supports are based on 150 PSI rated FRP pipe wall thicknesses. Allowable loads and designs for duct supports are based on 25 PSI rated FRP wall thicknesses. If the actual pressure ratings differ, the support designs can be altered to safely distribute the required loading.
 - 4) All supports are designed to maximize load distribution and to avoid point loading of the pipe at the support.
 - 5) Large diameter supports are custom engineered to meet specific load and functionality requirements. Expected loads and movements are required to engineer and optimize support configuration and design. Where large diameter supports are used without slide bearings allowing steel on steel contact, supports will need to be evaluated for axial loads due to increased frictional loading.
 - 6) Structural and supplementary steel structures are assumed to be near rigid. The length of the support should be centered on the supporting structures to limit the torsional loading of the steel. Flexibility in structural steel may induce unanticipated loads into the pipe/duct.
 - 7) The width of the supporting structural steel should be considered for support bearing. Structural or supplementary steel should provide a bearing surface of at least 50% of the support base length. If this is not possible, larger or thicker support base plates or stiffeners may be required. If additional installation plates or larger support base plates are needed, please specify size (length, width and thickness) with placement of order.
 - 8) Pipe/duct supports are available in sizes up to 60" in diameter. Larger sizes are available and are designed to suit the project requirements.
 - 9) All pipe/duct sizes are considered nominal. The outer diameter (O.D.) may vary depending on the manufacturer. The maximum O.D. must be specified with placement of order.
 - 10) Support dimensions are based on typical wall thicknesses and may vary depending on the actual O.D. and load requirements (See Note 3).
 - 11) Flange support dimensions for sizes up to 24" diameter pipe are based on ANSI B16.5 CL150 flange drilling and may vary depending on the actual drilling class and load requirements.
 - 12) Flange support dimensions for sizes above 24" diameter pipe are based on ASME B16.47 Series A CL150 flange drilling and may vary depending on the actual drilling class and load requirements.
 - 13) FRP flanges require a full back facing for use with flange plate supports.
 - 14) The standard material for RPS supports is carbon steel. Other materials such as aluminum, stainless steel and other alloys are available upon request.
 - 15) The standard finishes for RPS pipe/duct supports are:

1" to 30" diameter:	Hot dipped galvanized
36" diameter and up:	Painted per RPS painting specification (see page 89)
- Other types of paint finishes and Mill finish are available upon request.
Please specify desired finish with placement of order.
- 16) All saddle and clamp type supports include cushioning material to assure best fit and to minimize exterior pipe wear.
 - 17) Supports that require attachment to a structure are designed for welded installations. If bolted installations are preferred, please specify details with placement of order. See Support Options (Page 84) for details.
 - 18) Sizing of field welds for supports, clips, brackets, lugs, etc. to supporting structures are to be determined by others.
 - 19) Guide clips provided with the non-slide bearing type guide supports are designed to be field welded to the supporting structure. Guide clips for bolted installations to the supporting structure are available. Please specify the preferred attachment method with placement of order. See Figure O4 (Page 87) for details.
 - 20) The standard horizontal gap for guide and linestop supports is $\pm 1/8"$ with factory installed clips. Supports can be adjusted for specific displacements as required for project needs. Please specify with placement of order.

Pipe Supports

- 21) The upwards vertical gap for our guide and linestop style supports is $\pm 1/8"$ with factory installed clips. The vertical of supports with slide bearings may vary depending on the style of clip required. Where uplift or overturning is a concern, please provide vertical limit requirements or overturning loads at placement of order and supports can be adjusted to accommodate the specified limits and loads.
- 22) Slide bearings are recommended for supports with moderate to severe displacements and loads on systems having long runs with design pressures over 75 PSI for FRP or plastic pipe. Slide bearings are recommended for piping systems above 10" diameter where temperature gradients from ambient are greater than 60°F may occur. See Figure O2 (Page 84) for details. The incorporation of slide bearings is to minimize loads transferred to the supporting structure.
- 23) If pipe/duct requires insulated, slots can be incorporated into the support design to accommodate insulation banding. Please specify insulation thickness and details at placement of order.
- 24) Supplementary steel supporting structures are not included with RPS supports. Supplementary supporting structures can be provided upon request.
- 25) All materials such as pipe, duct, flanges and shear collars are not included with RPS supports. This material should be sourced from the piping manufacturer.
- 26) Shield banding and buckles are not included with RPS supports. Banding and buckles can be provided upon request. Material will be provided in bulk form.
- 27) Hanger hardware to suspend a support from a structure above is not included with RPS supports. Hanging hardware can be provided upon request.

Pipe Supports

Pictorial Index

Pipe Supports

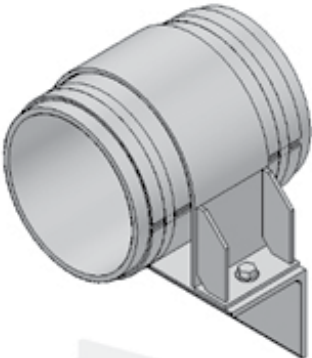
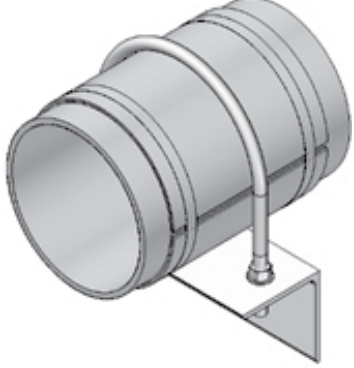
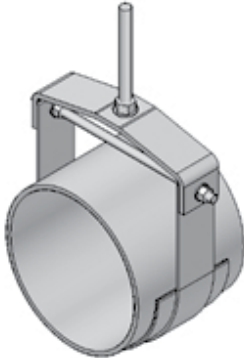
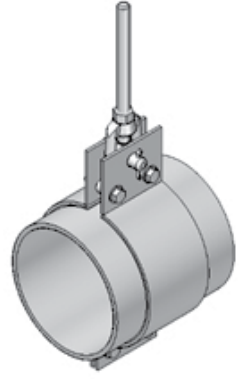
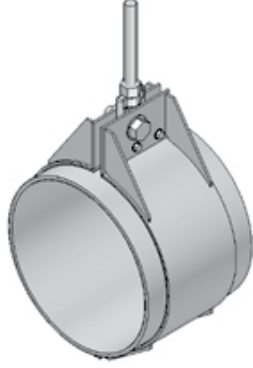
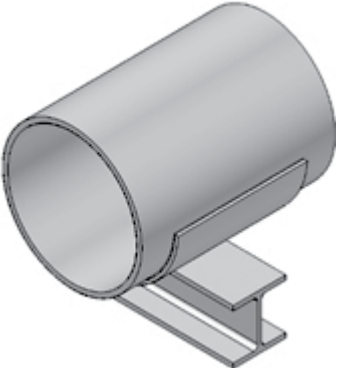
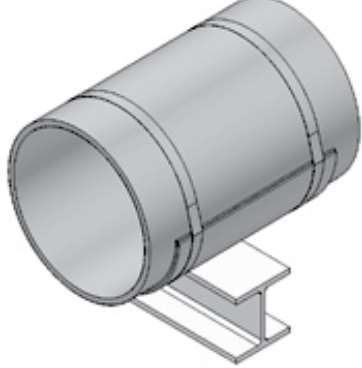
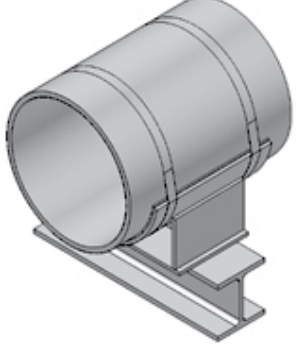
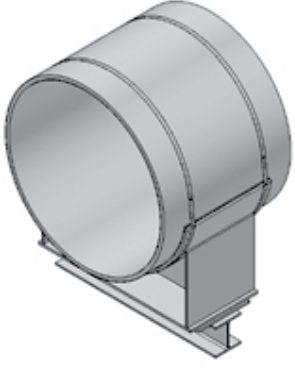
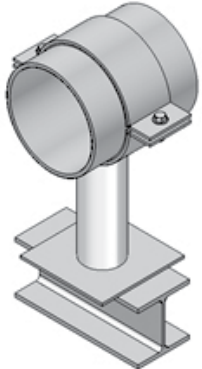
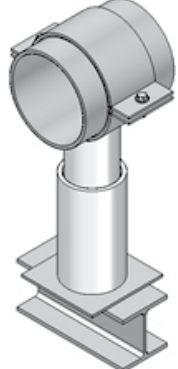
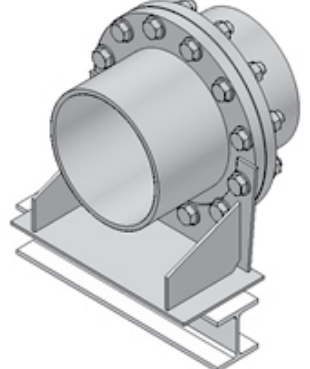
 <p>S1 U-Strap W/ Shield (1"-12" Dia.)</p>	 <p>S2 U-Bolt W. Shield (1"-12" Dia.)</p>	 <p>S4 Clevis Hanger (1"-18" Dia.)</p>	 <p>S5 Wide Clamp Hanger (1"-18" Dia.)</p>
 <p>S5 Wide Clamp Hanger (20"-60" Dia.)</p>	 <p>S7 FRP Wear Pad (1"-12" Dia.)</p>	 <p>S8 Slide Shield (1"-12" Dia.)</p>	 <p>S9 Pipe Cradle (1"-10" Dia.)</p>
 <p>S9B Pipe Cradle (12"-60" Dia.)</p>	 <p>S10 Pipe Stand - Fixed Height (1"-8" Dia.)</p>	 <p>S11 Pipe Stand - Adjustable Height (1"-8" Dia.)</p>	 <p>S12 Flange Slide (1"-10" Dia.)</p>

Pipe Supports

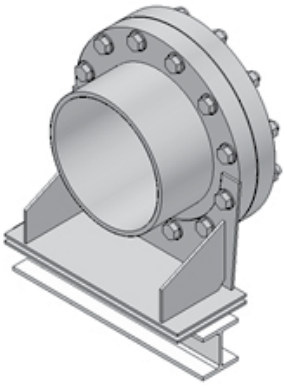

S12B
Flange Slide
(12"-30" Dia.)

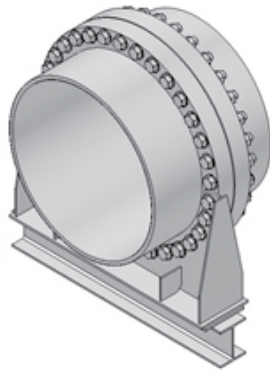

S12B
Flange Slide
(36"-60" Dia.)

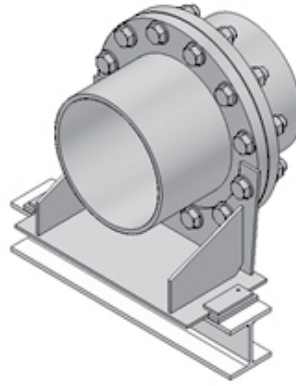

S13
Flange Guide
(1"-10" Dia.)

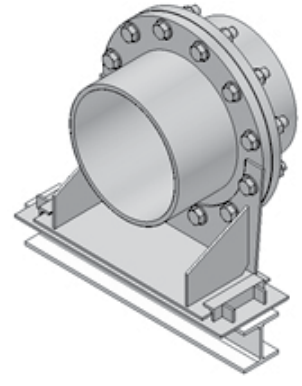

S13B
Flange Guide
(12"-30" Dia.)

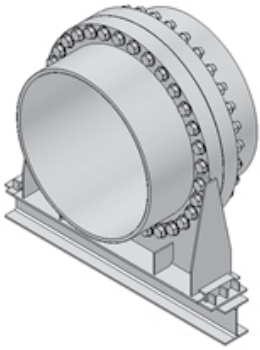

S13B
Flange Guide
(36"-60" Dia.)

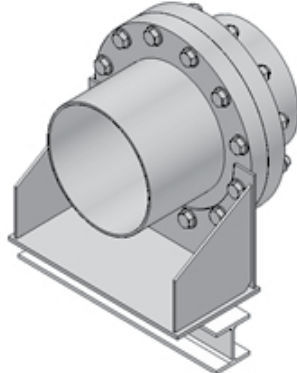

S14
Flange Anchor
(1"-30" Dia.)

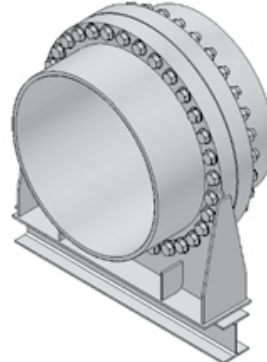

S14
Flange Anchor
(36"-60" Dia.)

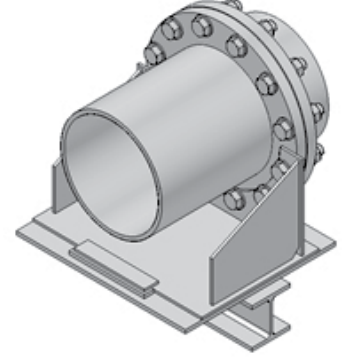

S15
Flange Linestop
(1"-10" Dia.)

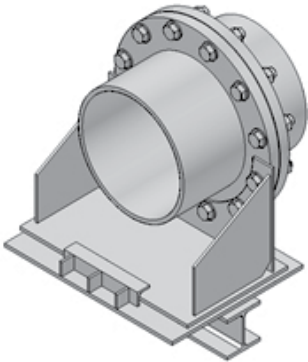

S15B
Flange Linestop
(12"-30" Dia.)

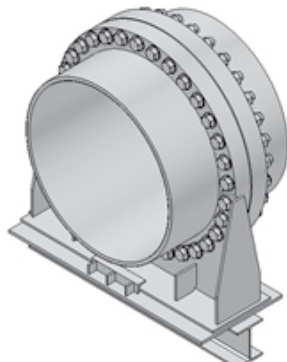

S15B
Flange Linestop
(36"-60" Dia.)

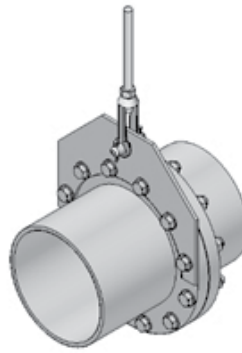

S16
Flange Hanger
(1"-18" Dia.)

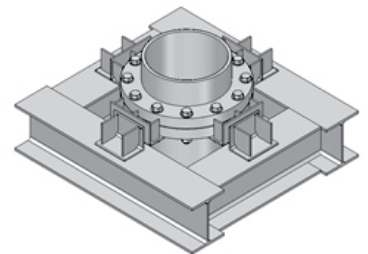

S17
Flange Riser Guide
(12"-30" Dia.)

Pipe Supports

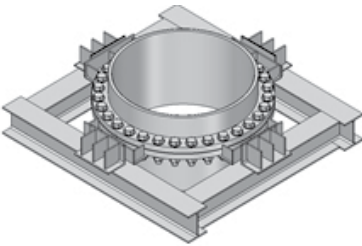
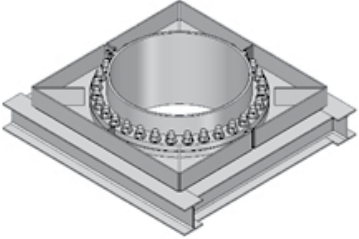
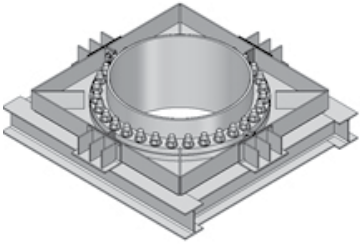
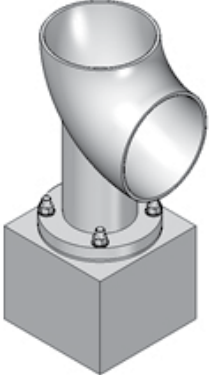
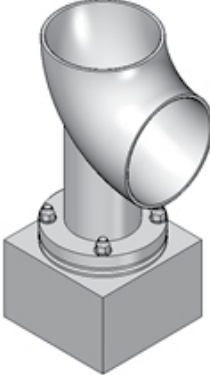
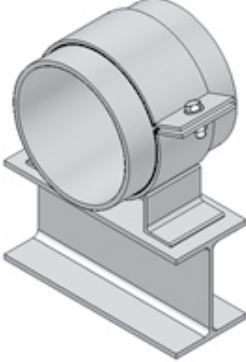
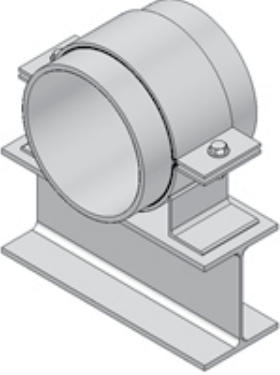
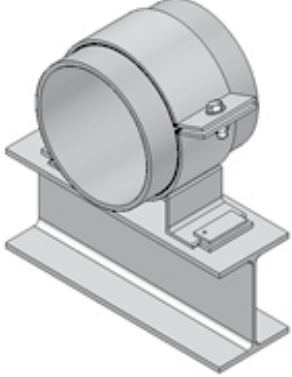
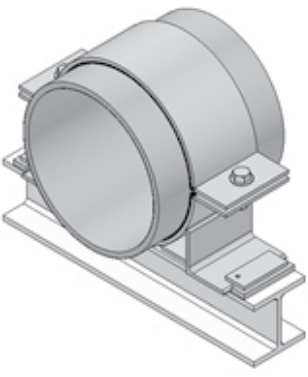
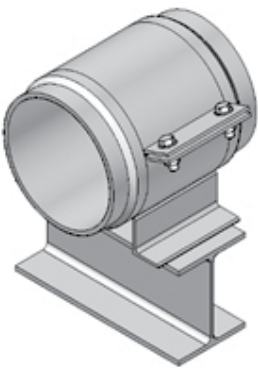
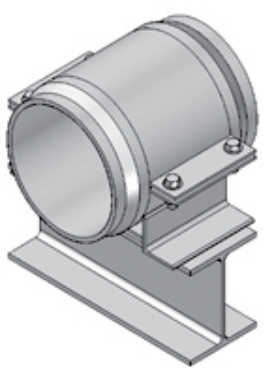
 <p>S17 Flange Riser Guide (36"-60" Dia.)</p>	 <p>S18 Flange Riser Support (12"-60" Dia.)</p>	 <p>S19 Flange Riser Support w/Guides (12"-60" Dia.)</p>	
 <p>P7 Elbow Support Slide Plate (2"-10" Dia.)</p>	 <p>P7B Elbow Support Slide Plate (12"-24" Dia.)</p>	 <p>P8 Base Slide (1"-10" Dia.)</p>	 <p>P8L Base Slide - Low Profile (1"-10" Dia.)</p>
 <p>P9 Base Guide (1"-10" Dia.)</p>	 <p>P9L Base Anchor - Low Profile (1"-10" Dia.)</p>	 <p>P10 Base Anchor (1"-10" Dia.)</p>	 <p>P10L Base Anchor - Low Profile (1"-10" Dia.)</p>

Pipe Supports

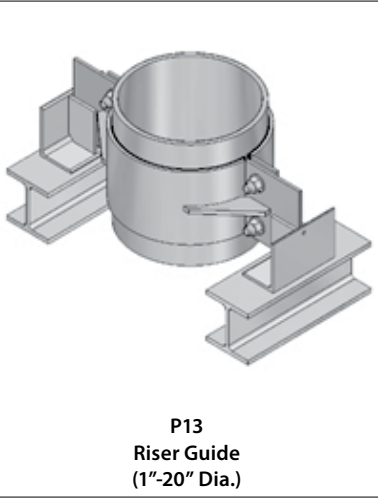
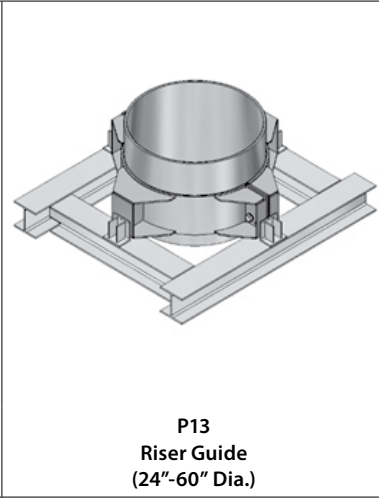
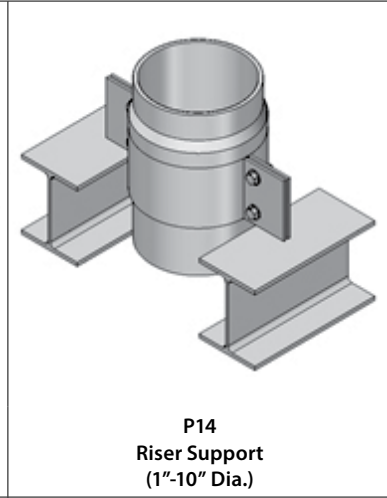
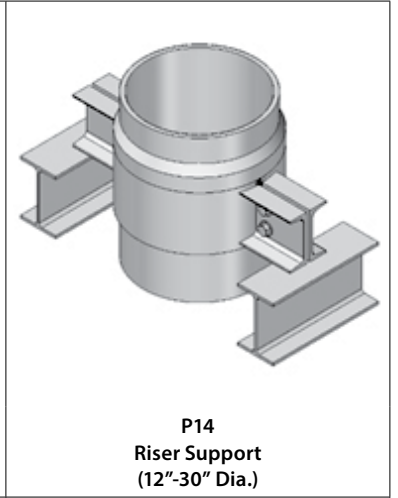
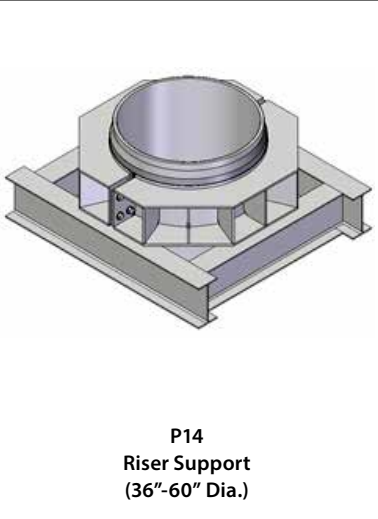
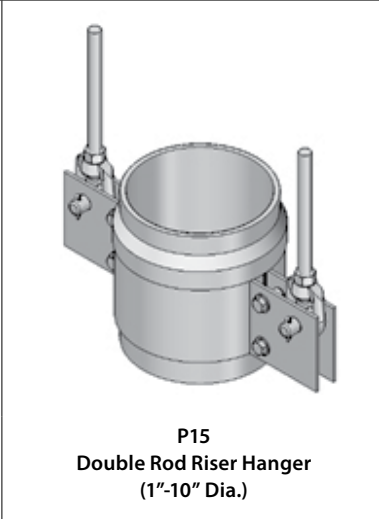
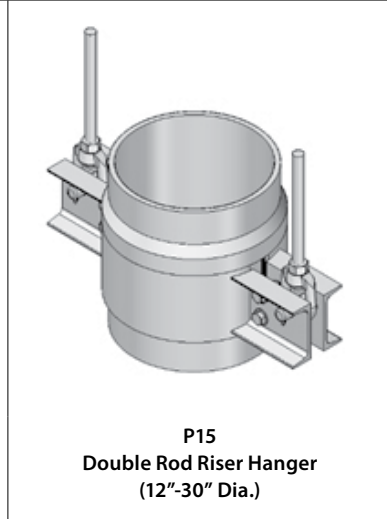
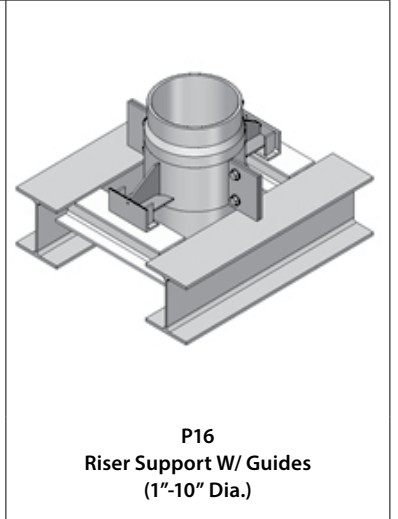
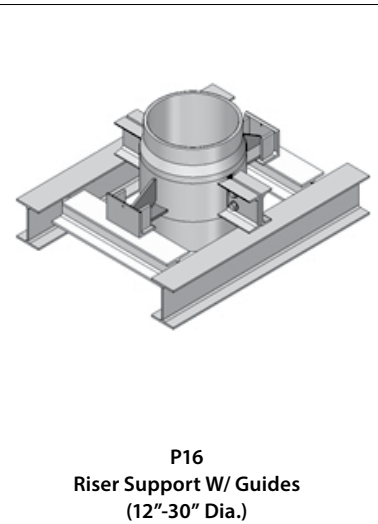
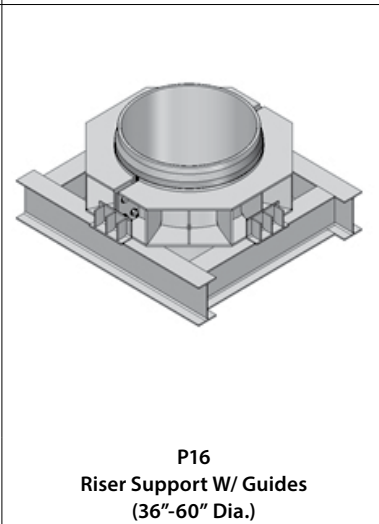
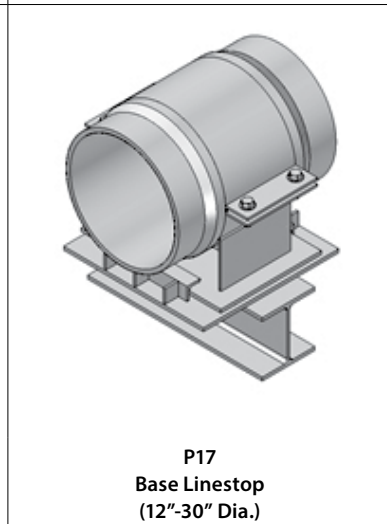
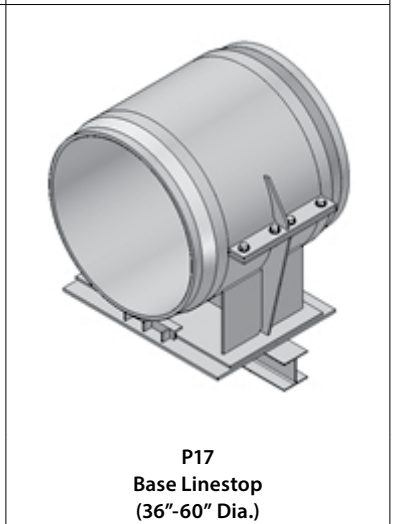
 <p>P13 Riser Guide (1"-20" Dia.)</p>	 <p>P13 Riser Guide (24"-60" Dia.)</p>	 <p>P14 Riser Support (1"-10" Dia.)</p>	 <p>P14 Riser Support (12"-30" Dia.)</p>
 <p>P14 Riser Support (36"-60" Dia.)</p>	 <p>P15 Double Rod Riser Hanger (1"-10" Dia.)</p>	 <p>P15 Double Rod Riser Hanger (12"-30" Dia.)</p>	 <p>P16 Riser Support W/ Guides (1"-10" Dia.)</p>
 <p>P16 Riser Support W/ Guides (12"-30" Dia.)</p>	 <p>P16 Riser Support W/ Guides (36"-60" Dia.)</p>	 <p>P17 Base Linestop (12"-30" Dia.)</p>	 <p>P17 Base Linestop (36"-60" Dia.)</p>

Pipe Supports

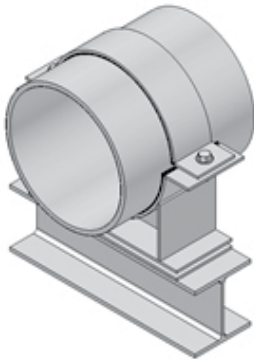

P18
Base Slide
(12"-30" Dia.)

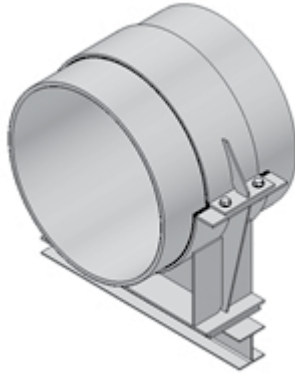

P18
Base Slide
(36"-60" Dia.)

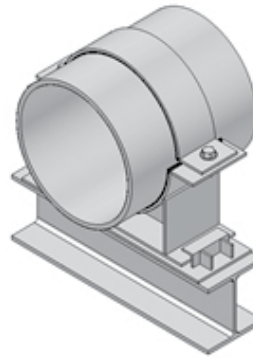

P19
Base Guide
(12"-30" Dia.)

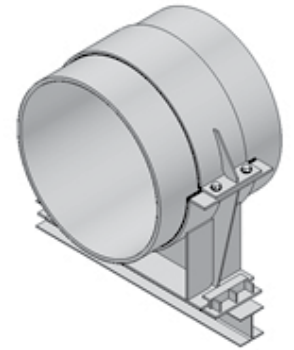

P19
Base Guide
(36"-60" Dia.)

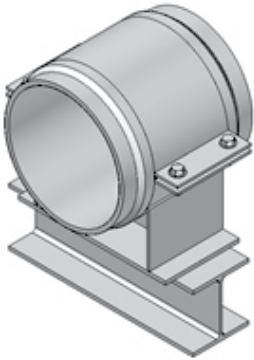

P20
Base Anchor
(12"-30" Dia.)

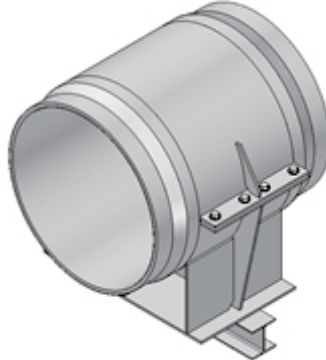

P20
Base Anchor
(36"-60" Dia.)

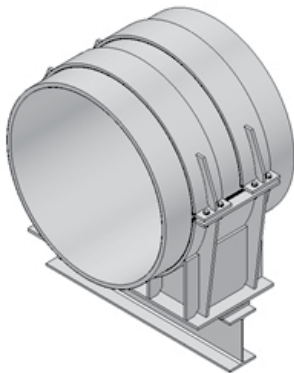

XL12
Extra Large Slide
(66"-108" Dia.)

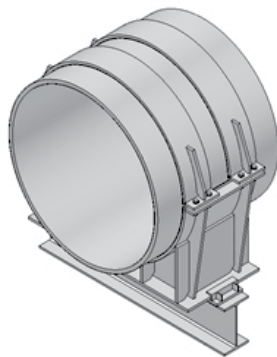

XL13
Extra Large Guide
(66"-108" Dia.)

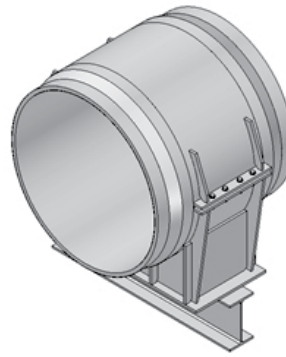

XL14
Extra Large Anchor
(66"-108" Dia.)

Pipe Supports

Pictorial Index Duct Supports

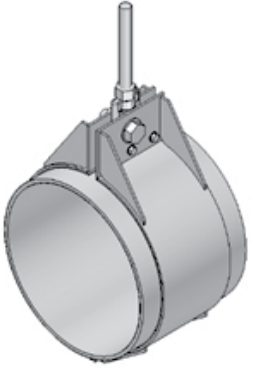
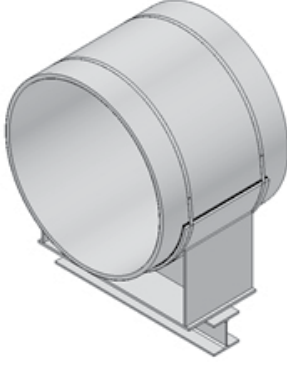
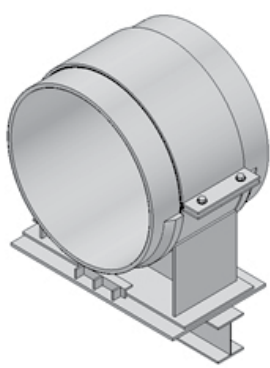
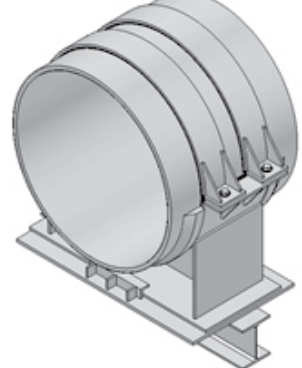
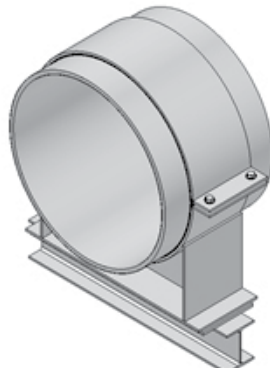
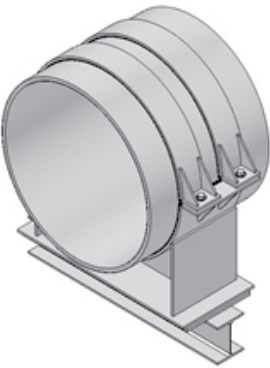
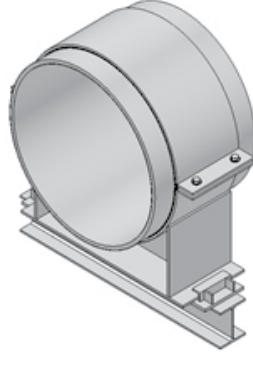
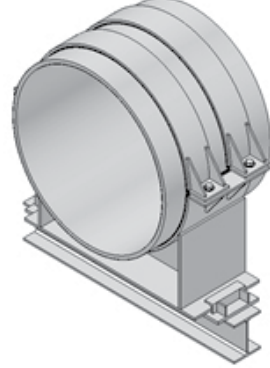
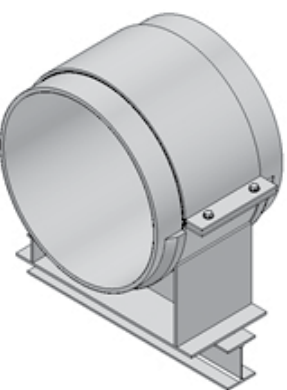
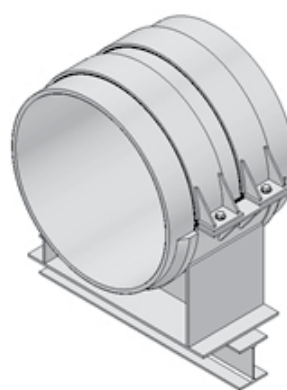
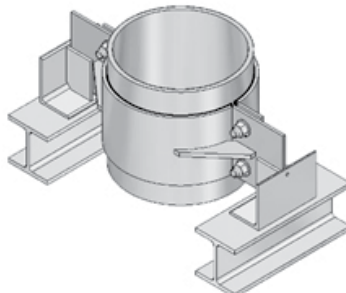
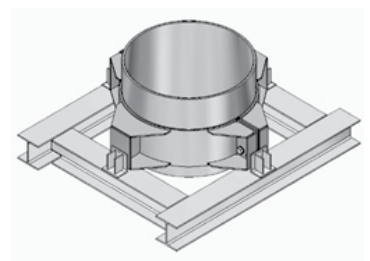
 <p>D1 Duct Clamp Hanger (20"-60" Dia.)</p>	 <p>D3 Duct Cradle Base Slide (20"-60" Dia.)</p>	 <p>D4 Duct Base Linestop (20"-36" Dia.)</p>	 <p>D4 Duct Base Linestop (42"-60" Dia.)</p>
 <p>D5 Duct Base Slide (20"-36" Dia.)</p>	 <p>D5 Duct Base Slide (42"-60" Dia.)</p>	 <p>D6 Duct Base Guide (20"-36" Dia.)</p>	 <p>D6 Duct Base Guide (42"-60" Dia.)</p>
 <p>D7 Duct Base Anchor (20"-36" Dia.)</p>	 <p>D7 Duct Base Anchor (42"-60" Dia.)</p>	 <p>D16 Duct Riser Guide (20"-30" Dia.)</p>	 <p>D16 Duct Riser Guide (36"-60" Dia.)</p>

Pipe Supports

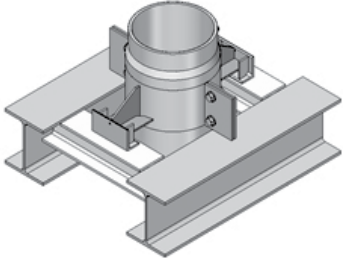

D17
Duct Riser Support W/ Guides
(20"-30" Dia.)

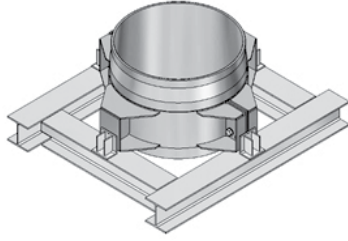

D17
Duct Riser Support W/ Guides
(36"-60" Dia.)

Pipe Supports

Pipe Supports

Figure S1: U-Strap W/ Shield

(1"-12" Diameter)

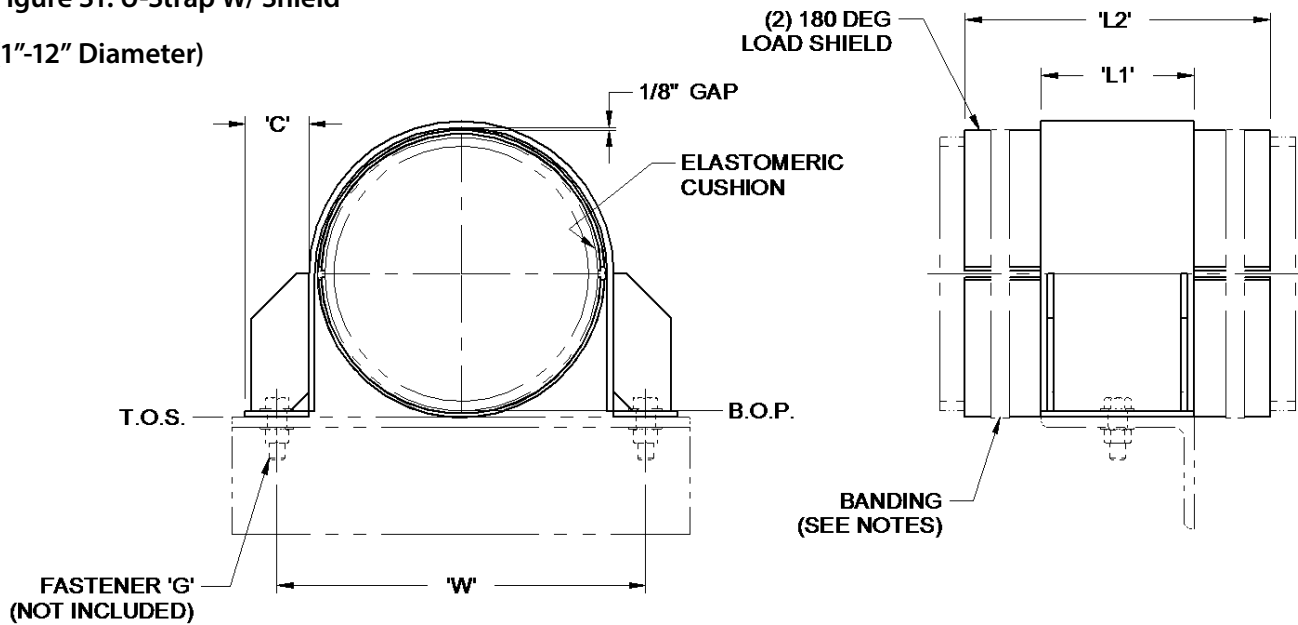

Finish:

Electroplated, hot-dipped galvanized

See General Note 15, page 5.

Service:

To provide wear protection for pipe while allowing freedom of axial movement and limiting lateral movement

Material:

Carbon steel

See General Note 14, page 5.

Notes:

Base width (W) must be fully supported. Dimensions are based on typical 150 PSI rated pipe and may vary depending on the actual O.D. and load requirements. Load shield rests on supporting structure. Banding can be provided (in bulk) upon request. See General Note 26, page 6.

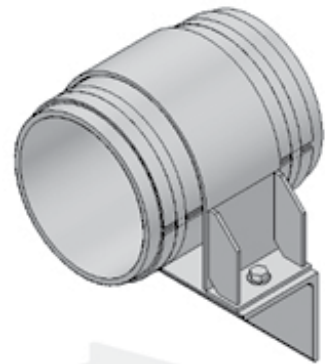

Pipe Size [in]	C [in]	G [in]	L1 [in]	L2 [in]	W [in]	Allowable Loads [lb]	
						Lateral	Vertical
1	1 1/2	3/8	3	12	3 7/8	80	80
1 1/2	1 1/2	3/8	3	12	4 3/8	90	90
2	2	3/8	4	12	5 3/8	100	110
3	2	3/8	4	12	6 3/8	200	200
4	2	3/8	4	12	7 1/2	300	280
6	2	1/2	4	12	9 7/8	600	540
8	2	1/2	4	12	11 7/8	700	800
10	2 1/2	5/8	6	12	14 1/2	1300	1200
12	2 1/2	5/8	6	12	16 3/4	1300	1600

Pipe Supports

Figure S2: U-Strap W/ Shield

(1"-12" Diameter)

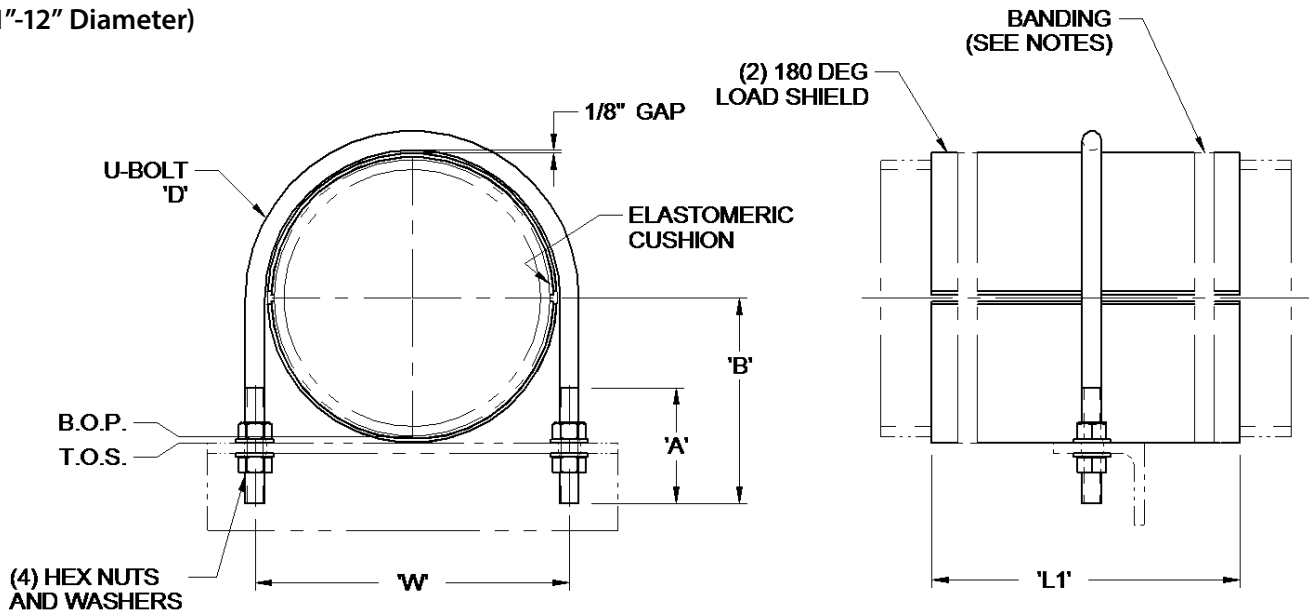

Finish:

Electroplated, hot-dipped galvanized

See General Note 15, page 5.

Service:

To provide wear protection for pipe while allowing freedom of axial movement and limiting lateral movement

Material:

Carbon steel

See General Note 14, page 5.

Notes:

Base width (W) must be fully supported. Dimensions are based on typical 150 PSI rated pipe and may vary depending on the actual O.D. and load requirements. Load shield rests on supporting structure. Banding can be provided (in bulk) upon request. See General Note 26, page 6.

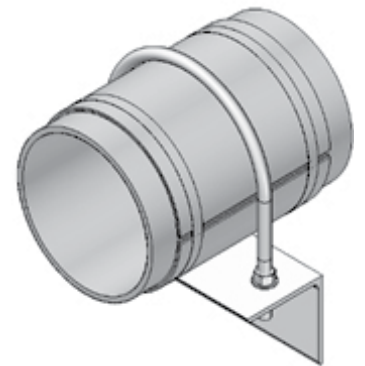

Pipe Size [in]	A [in]	B [in]	D [in]	L1 [in]	W [in]	Allowable Loads [lb]	
						Lateral	Vertical
1	1 3/4	2	3/8	12	2 3/8	20	80
1 1/2	1 7/8	2 1/4	3/8	12	2 7/8	20	90
2	2 1/4	2 3/4	3/8	12	3 3/8	20	110
3	3	3 1/2	1/2	12	4 1/2	45	200
4	3	4	1/2	12	5 5/8	70	280
6	3 1/2	5 1/2	5/8	12	8	150	540
8	3 1/2	6 1/2	5/8	12	10	170	800
10	4	8	3/4	12	12 1/4	200	1200
12	4 1/2	9 1/2	3/4	12	14 1/2	210	1600

Pipe Supports

Figure S4: Clevis Hanger
(1"-18" Diameter)

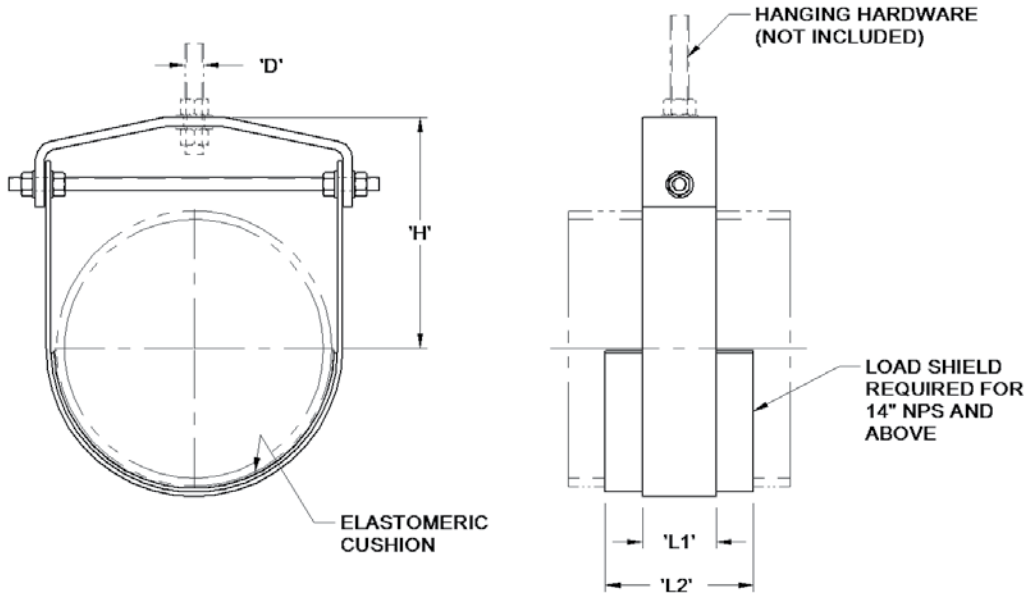

Finish:

Hot-dipped galvanized

See General Note 15, page 5.

Service:

To support weight of pipe from above while allowing freedom of movement

Material:

Carbon steel

See General Note 14, page 5.

Notes:

Dimensions are based on typical 150 PSI rated pipe and may vary depending on the actual O.D. and load requirements. Hanging hardware is available upon request. See General Notes, pages 5 and 6.

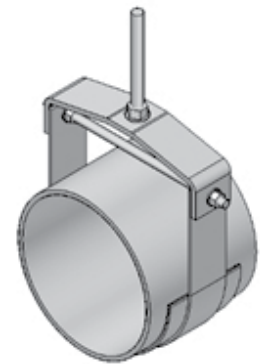

Pipe Size [in]	D [in]	H [in]	L1 [in]	L2 [in]	Allowable Loads [lb]
					Vertical
1	3/8	3 1/4	3	----	100
1 1/2	3/8	3 1/4	3	----	150
2	3/8	3 1/4	3	----	240
3	1/2	4 1/2	3	----	315
4	5/8	5 1/2	3	----	420
6	3/4	7	4	----	840
8	3/4	8 1/2	4	----	1120
10	7/8	10	6	----	1800
12	7/8	11 1/2	6	----	2160
14	1	12 1/2	4	8	2800
16	1	14	4	8	3300
18	1	16	4	10	3500

Pipe Supports

Figure S5: Wide Clamp Hanger

(1"-18" Diameter)

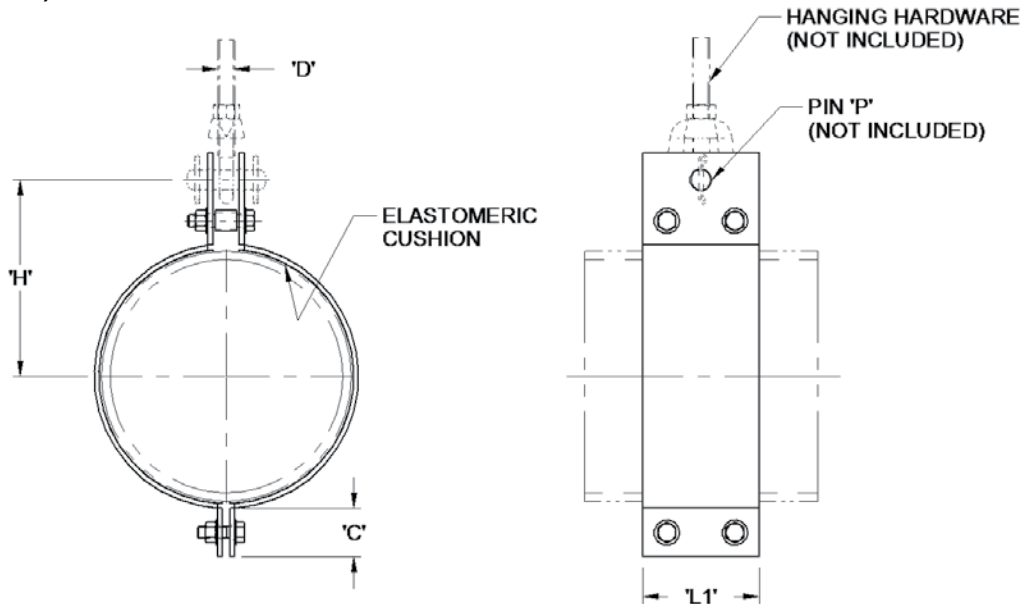

Finish:

Hot-dipped galvanized

See General Note 15, page 5.

Service:

To support weight of pipe from above while allowing freedom of movement

Material:

Carbon steel

See General Note 14, page 5.

Notes:

Dimensions are based on typical 150 PSI rated pipe and may vary depending on the actual O.D. and load requirements. Hanging hardware is available upon request. See page 18 for sizes 20" - 60". See General Notes, pages 5 and 6.

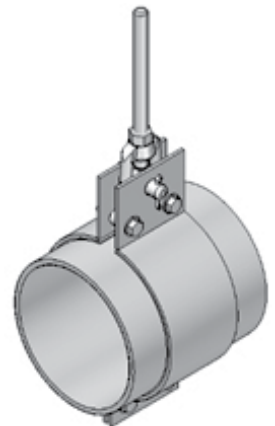

Pipe Size [in]	C [in]	D [in]	H [in]	L1 [in]	P [in]	Allowable Loads [lb]
						Vertical
1	1 1/2	3/8	4	3	1/2	100
1 1/2	1 1/2	3/8	4 1/4	3	1/2	150
2	1 1/2	3/8	4 9/16	3	1/2	240
3	1 1/2	1/2	5 1/16	3	5/8	315
4	1 1/2	5/8	5 9/16	3	3/4	420
6	2	3/4	6 3/4	4	7/8	840
8	2	3/4	7 3/4	4	7/8	1120
10	2 1/2	7/8	9 1/16	6	1	1800
12	2 1/2	7/8	10 1/8	6	1	2160
14	2 1/2	1	11 1/4	8	1 1/8	3360
16	2 1/2	1	12 7/16	8	1 1/8	3840
18	3	1	13 11/16	10	1 1/8	5400

Pipe Supports

Figure S5: Wide Clamp Hanger
(20"-60" Diameter)

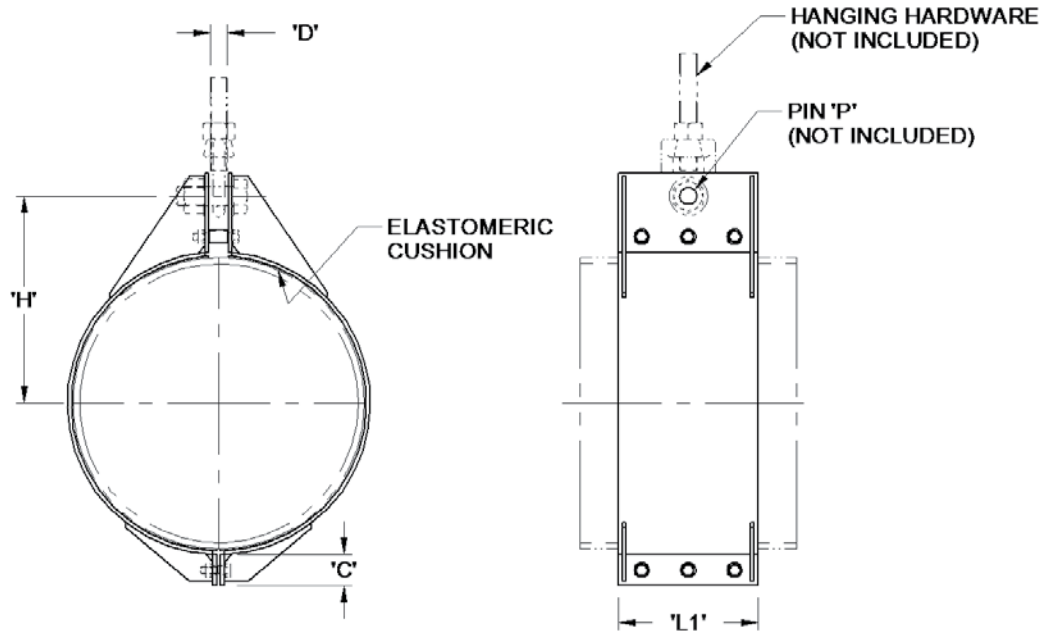

Finish:
20" – 30": Hot-dipped galvanized
36" – 60": Painted
See General Note 15, page 5.

Service:
To support weight of pipe from above while allowing freedom of movement

Material:
Carbon steel
See General Note 14, page 5.

Notes:
Dimensions are based on typical 150 PSI rated pipe and may vary depending on the actual O.D. and load requirements. Hanging hardware is available upon request. See page 17 for sizes 1" - 18". See General Notes, pages 5 and 6

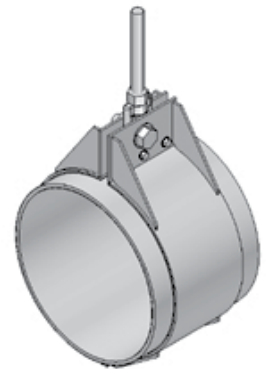

Pipe Size [in]	C [in]	D [in]	H [in]	L1 [in]	P [in]	Allowable Loads [lb]
						Vertical
20	3	1 1/4	15 3/4	10	1 3/8	8000
24	3	1 1/2	18 3/16	12	1 5/8	10000
30	3	2	22	15	2 1/4	15000
36	4	2 1/4	26	18	2 1/2	23000
42	4	2 1/2	30 3/8	21	2 3/4	28000
48	4	2 3/4	35 1/4	24	3	36000
54	4	3	37 3/16	27	3 1/4	40000
60	4	3	40 1/4	30	3 1/4	45000

Pipe Supports

**Figure S7: FRP Wear Pad
(1"-12" Diameter)**

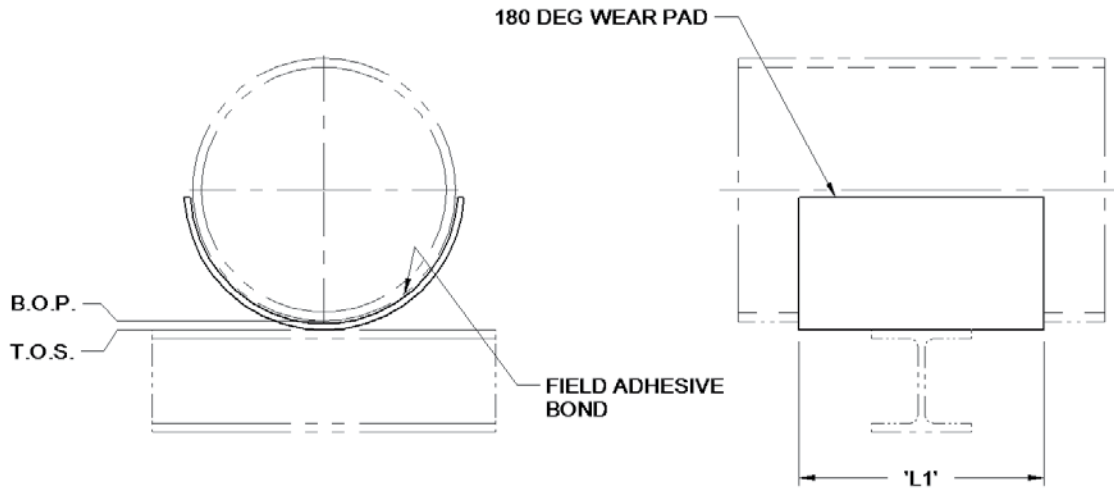

Finish:

Plain, painted

Service:

To provide wear protection for FRP pipe while allowing freedom of movement

Material:

Fiberglass reinforced plastic

Notes:

Bonded to FRP pipe. Adhesive to be ordered separately. Wear pad rests on supporting structure. See General Notes, pages 5 and 6.

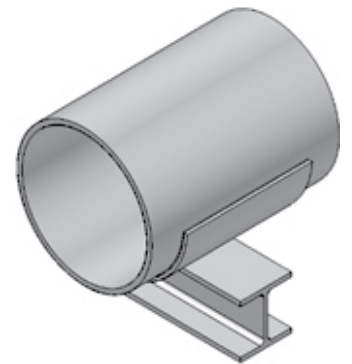

Pipe Size [in]	L1 [in]	Allowable Loads [lb]
		Vertical
1	4	50
1 1/2	4	60
2	4	75
3	6	130
4	6	180
6	8	350
8	8	520
10	10	780
12	12	1200

Pipe Supports

Figure S8: Slide Shield
(1"-12" Diameter)

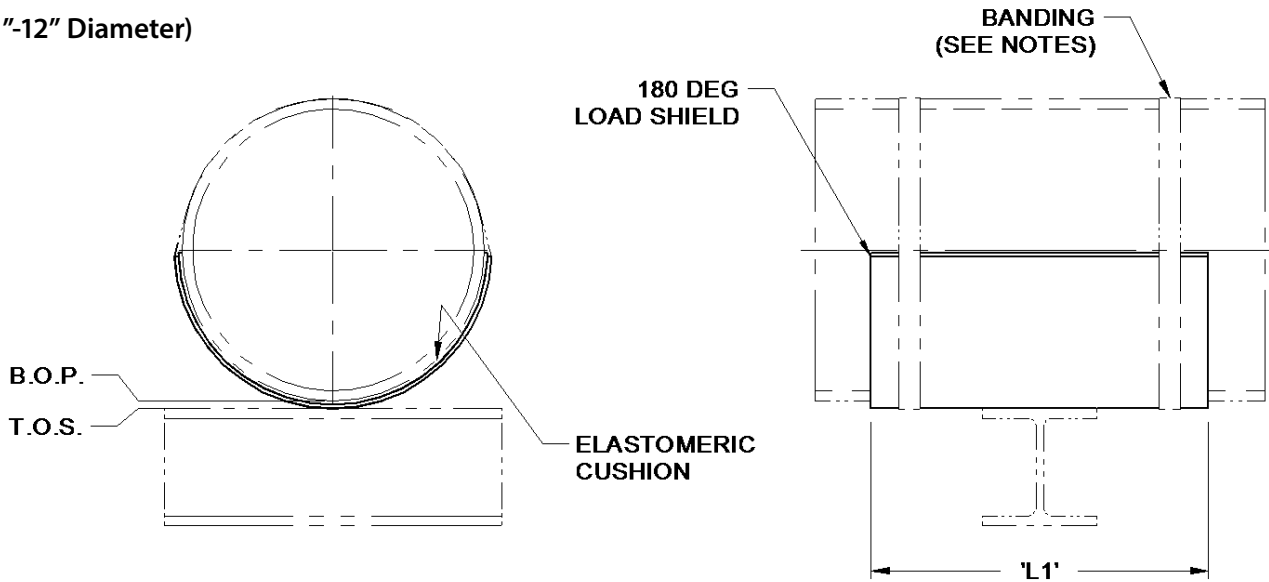

Finish:
Electroplated, hot-dipped galvanized
See General Note 15, page 5.

Service:
To provide wear protection for pipe while allowing freedom of movement

Material:
Carbon steel
See General Note 14, page 5.

Notes:
Dimensions are based on typical 150 PSI rated pipe and may vary depending on the actual O.D. and load requirements. Load shield rests on supporting structure. Banding can be provided (in bulk) upon request. See General Note 26, page 6.

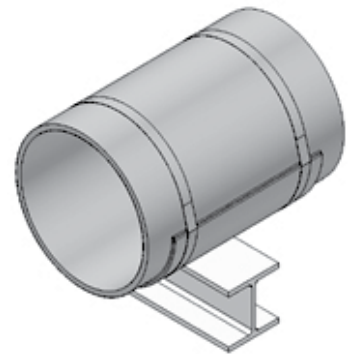

Pipe Size [in]	L1 [in]	Allowable Loads [lb]
		Vertical
1	12	80
1 1/2	12	90
2	12	110
3	12	200
4	12	280
6	12	540
8	12	800
10	12	1200
12	12	1600

Pipe Supports

Figure S9: Pipe Cradle

(1"-10" Diameter)

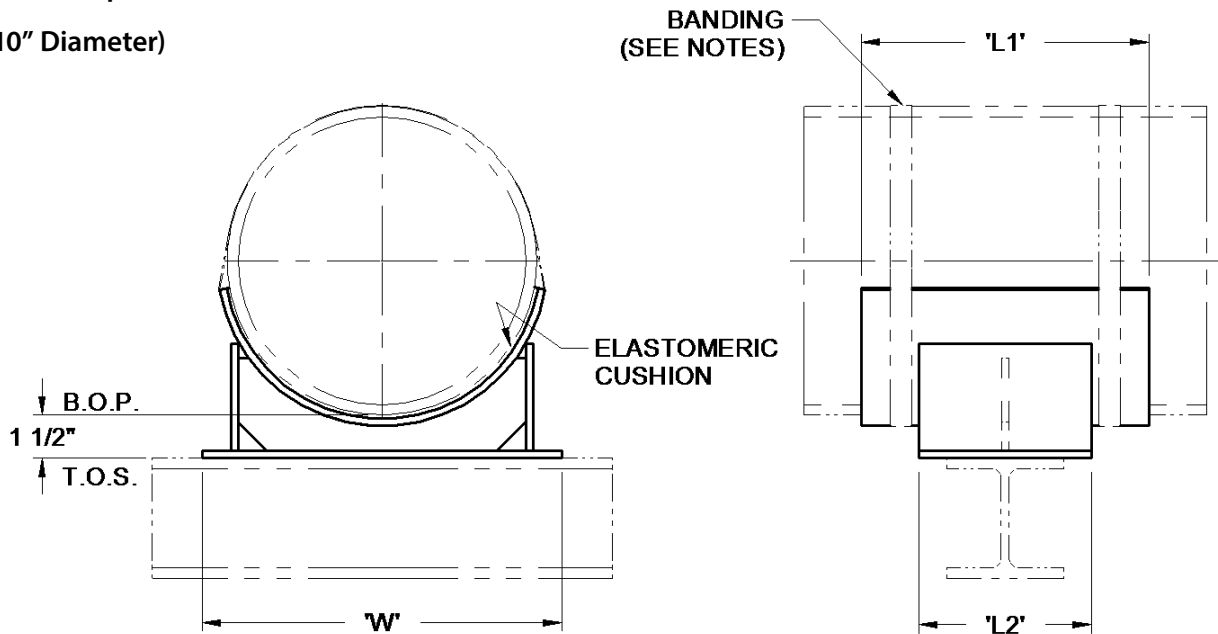

Finish:

Hot-dipped galvanized

See General Note 15, page 5.

Service:

To support weight of pipe while allowing freedom of movement

Material:

Carbon steel.

See General Note 14, page 5.

Notes:

Dimensions are based on typical 150 PSI rated pipe and may vary depending on the actual O.D. and load requirements. Banding can be provided (in bulk) upon request. See page 22 for sizes 12" – 60". See General Note 26 on page 6.

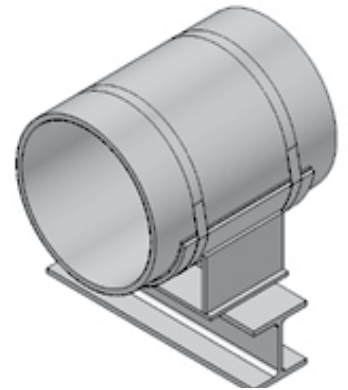

Pipe Size [in]	L1 [in]	L2 [in]	W [in]	Allowable Loads [lb]
				Vertical
1	6	4	4 1/2	120
1 1/2	6	4	5	150
2	8	4	4	170
3	8	4	4 1/2	250
4	8	4	5 1/2	320
6	10	6	7 1/2	650
8	10	6	9 1/2	1000
10	10	6	11 1/4	1500

Pipe Supports

Figure S9B: Pipe Cradle
(12"-60" Diameter)

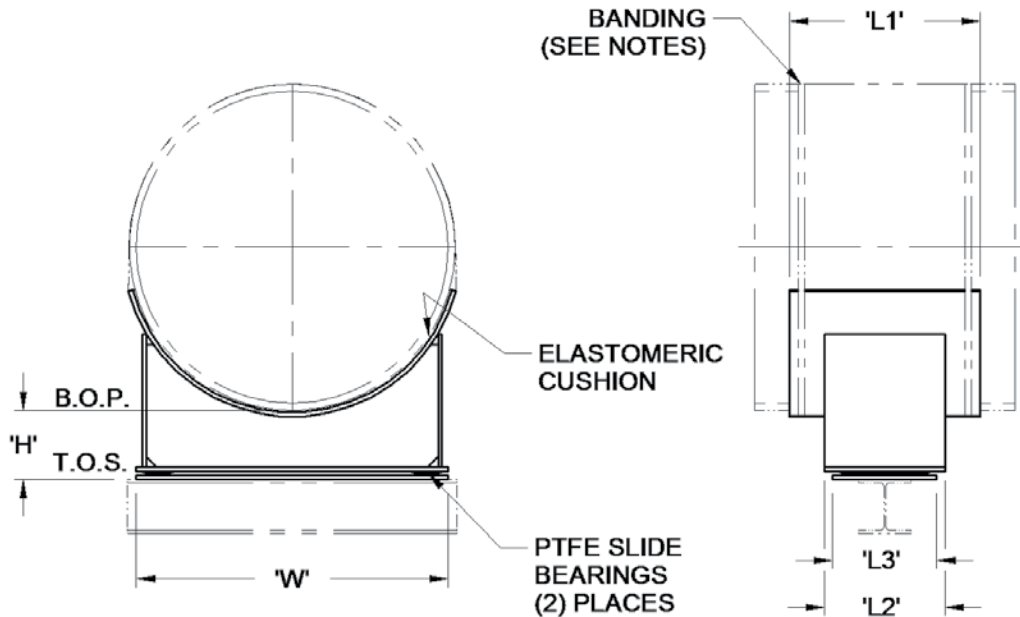

Finish:
20" – 30": Hot-dipped galvanized
36" – 60": Painted
See General Note 15, page 5.

Service:
To support weight of pipe while allowing freedom of movement

Material:
Carbon steel
See General Note 14, page 5.

Notes:
Support is provided with a base plate for welded installations. Base plates for bolted installation are available upon request. Provide bolting arrangement with placement of order. Dimensions are based on typical 150 PSI rated pipe and may vary depending on the actual O.D. and load requirements. PTFE slide bearings are recommended for pipe sizes above 10" NPS. Banding can be provided (in bulk) upon request. See page 21 for sizes 1" – 10". See General Note 26, page 6.

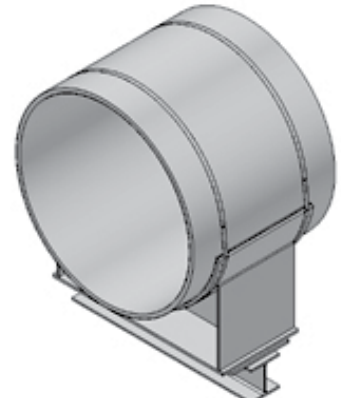

Pipe Size [in]	H [in]	L1 [in]	L2 [in]	L3 [in]	W [in]	Allowable Loads [lb]
						Vertical
12	3	12	8	8	13 1/8	1800
14	3	12	8	8	15	2400
16	3	12	8	8	16 1/2	3000
18	3	12	8	8	19	3700
20	3 1/4	12	8	8	21	4300
24	3 1/4	14	10	8	25	6200
30	4	16	12	10	30	9000
36	8	20	16	12	36	13000
42	8	22	18	12	42	16000
48	8	24	20	12	48	23000
54	8	26	22	12	54	28000
60	8	28	24	12	60	32000

Pipe Supports

Figure S10: Pipe Stand - Fixed Height

(1"-8" Diameter)

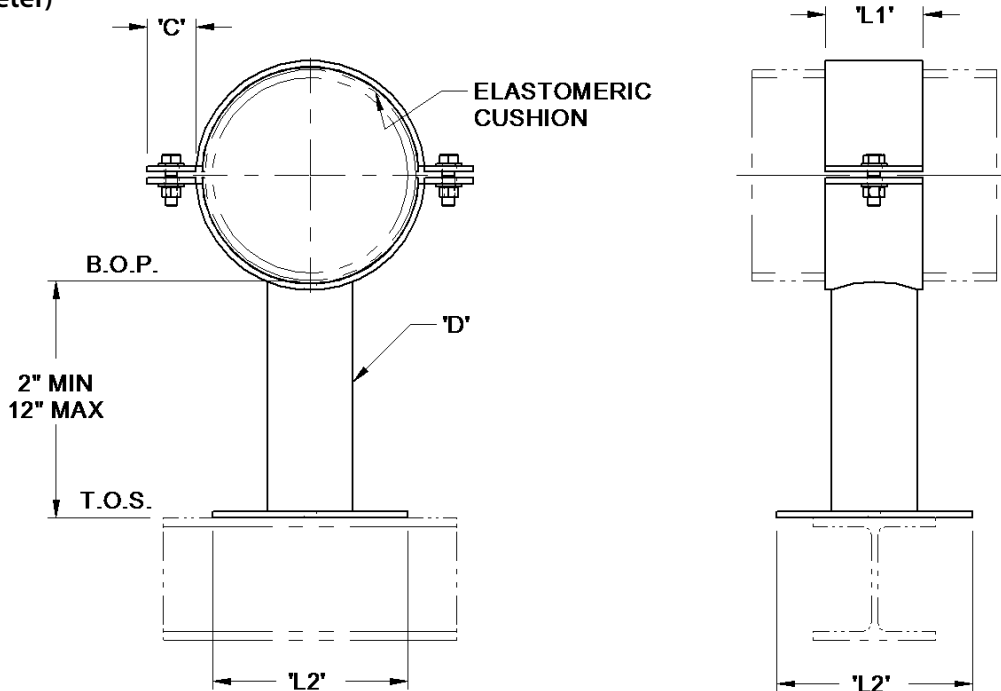

Finish:

Hot-dipped galvanized

See General Note 15, page 5.

Service:

Fixed height pipe stand to support weight of pipe while allowing freedom of movement

Material:

Carbon steel

See General Note 14, page 5.

Notes:

Not designed for axial or lateral loads. Dimensions are based on typical 150 PSI rated pipe and may vary depending on the actual O.D. and load requirements. Specify desired height upon placement of order. See General Notes, pages 5 and 6.

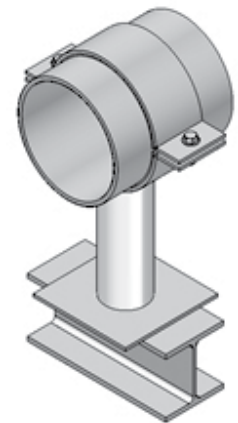

Pipe Size [in]	C [in]	D [NPS]	L1 [in]	L2 [in]	Allowable Loads [lb]
					Vertical
1	1 1/2	1 1/2	3	6	150
1 1/2	1 1/2	1 1/2	3	6	180
2	1 1/2	2	3	6	220
3	1 1/2	2	3	6	320
4	1 1/2	2	3	6	420
6	2	3	4	8	800
8	2	3	4	8	1050

Pipe Supports

Figure S11: Pipe Stand - Adjustable Height
(1"-8" Diameter)

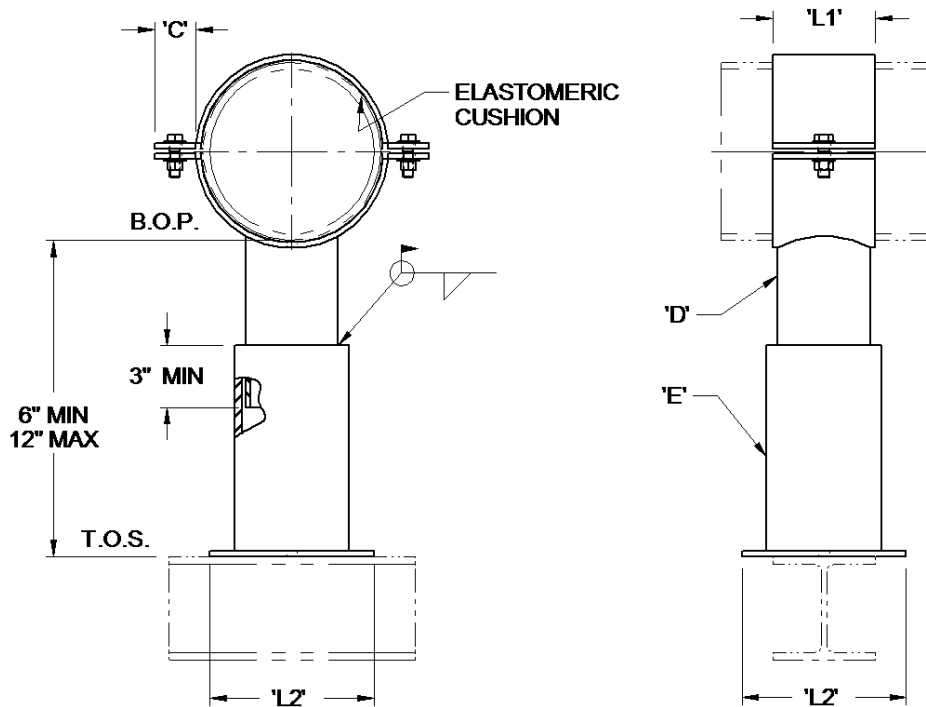

Finish:
Hot-dipped galvanized
See General Note 15, page 5.

Service:
Adjustable height pipe stand to support weight of pipe while allowing freedom of movement

Material:
Carbon steel

See General Note 14, page 5.

Notes:
Not designed for axial or lateral loads. Dimensions are based on typical 150 PSI rated pipe and may vary depending on the actual O.D. and load requirements. Specify desired height upon placement of order. See General Notes, pages 5 and 6.

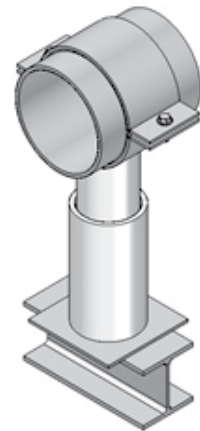

Pipe Size [in]	C [in]	D[NPS]	E [NPS]	L1 [in]	L2 [in]	Allowable Loads [lb]
						Vertical
1	1 1/2	1 1/2	2	3	6	150
1 1/2	1 1/2	1 1/2	2	3	6	180
2	1 1/2	2 1/2	3	4	6	220
3	1 1/2	2 1/2	3	4	6	320
4	1 1/2	2 1/2	3	4	6	420
6	2	4	5	5	8	800
8	2	4	5	5	8	1050

Pipe Supports

Figure S12: Flange Slide

(1"-10" Diameter)

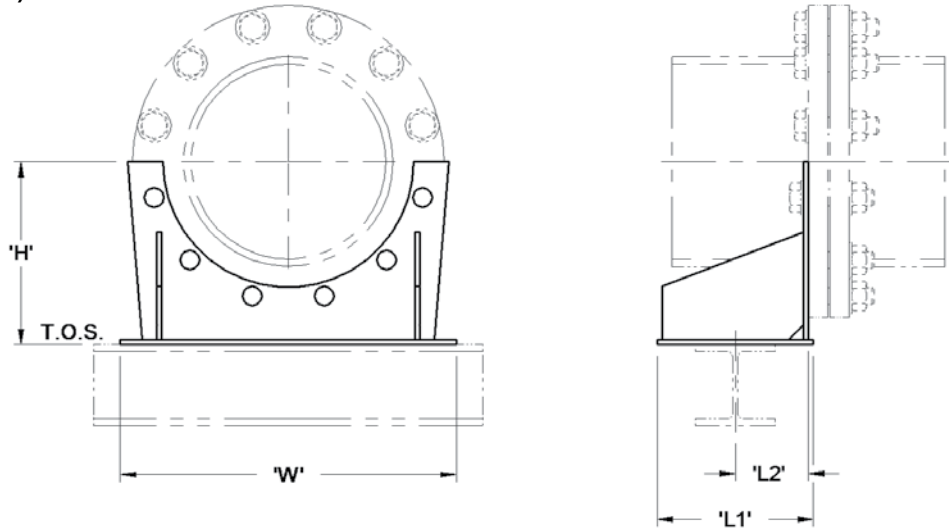

Finish:

Hot-dipped galvanized

See General Note 15, page 5.

Service:

To support weight of pipe, valves or equipment while allowing freedom of movement

Material:

Carbon steel

See General Note 14, page 5.

Notes:

Dimensions are based on ANSI B16.5 CL150 flange drilling and may vary depending on actual drilling requirements. FRP flanges require a full back-face. See page 26 for sizes 12" – 30". See page 27 for sizes 36" – 60". See General Notes, pages 5 and 6.

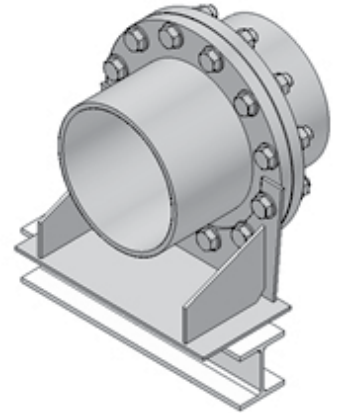

Pipe Size [in]	H [in]	L1 [in]	L2 [in]	W [in]	Allowable Loads [lb]
					Vertical
1	3 3/4	3	1 1/4	5 1/2	200
1 1/2	4 1/4	3	1 1/4	6	300
2	4 5/8	4	1 3/4	6	500
3	5 1/4	4	1 3/4	7 1/2	700
4	6	4	1 3/4	10 1/4	900
6	7	6	2 3/4	12 1/4	1500
8	8 1/4	6	2 3/4	14 1/4	1800
10	9 3/8	8	3 3/4	17 1/4	2200

Pipe Supports

Figure S12B: Flange Slide
(12"-30" Diameter)

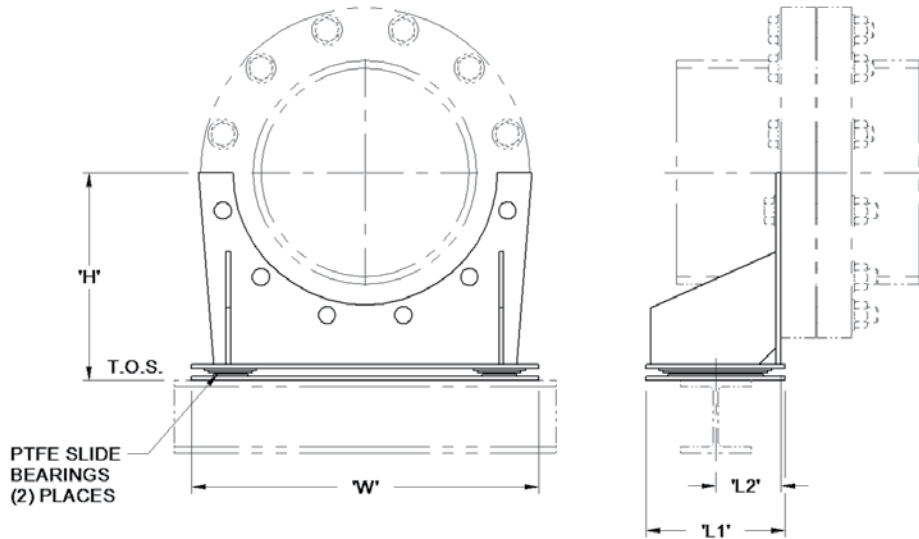

Finish:

Hot-dipped galvanized
See General Note 15, page 5.

Service:

To support weight of pipe, valves or equipment, while allowing freedom of movement

Material:

Carbon steel
See General Note 14, page 5.

Notes:

Support is provided with a base plate for welded installations. Base plates for bolted installations are available upon request. Provide bolting arrangement with placement of order. Dimensions are based on ANSI B16.5 or ASME B16.47 Series A CL 150 flange drilling and may vary depending on actual drilling requirements. PTFE slide bearings are recommended for pipe sizes above 10" NPS. FRP flanges require a full back-face. See page 25 for sizes 1"-10". See page 27 for sizes 36" - 60". See General Notes, pages 5 and 6.

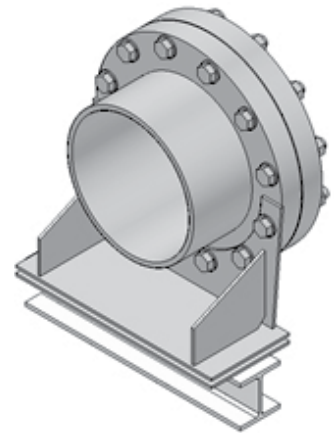

Pipe Size [in]	H [in]	L1 [in]	L2 [in]	W [in]	Allowable Loads [lb]
					Vertical
12	12	8	3 3/4	20	2800
14	12 7/8	8	3 3/4	21 1/2	3200
16	14 1/8	8	3 3/4	24 1/2	4200
18	15 3/8	8	3 3/4	26	5300
20	17 1/2	10	4 5/8	29 1/8	6500
24	19 3/4	10	4 5/8	32 3/4	8900
30	23 5/8	10	4 5/8	36 3/4	11000

Pipe Supports

Figure S12B: Flange Slide

(36"-60" Diameter)

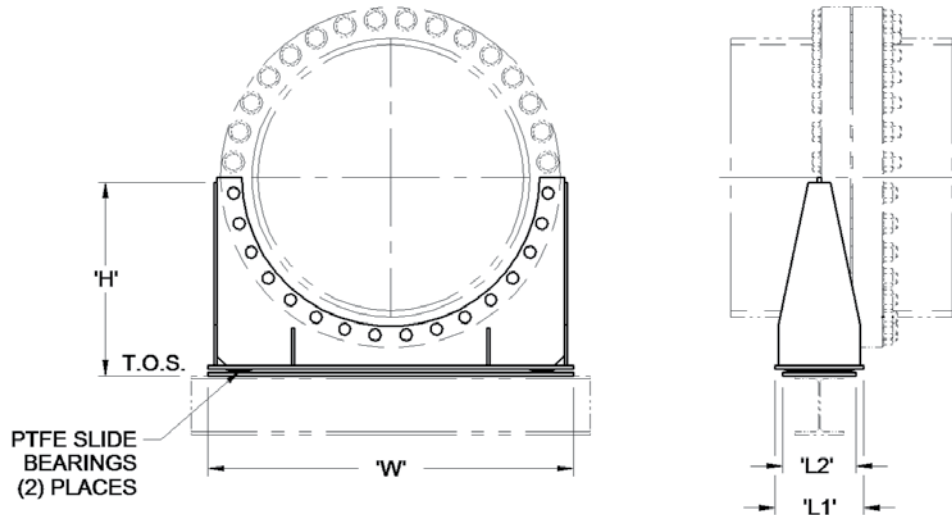

Finish:

Painted

See General Note 15, page 5.

Service:

To support weight of pipe, valve or equipment while allowing freedom of movement

Material:

Carbon steel

See General Note 14, page 5.

Notes:

Support is provided with a base plate for welded installations. Base plates for bolted installations are available upon request. Provide bolting arrangement with placement of order. Dimensions are based on ASME B16.47 Series A CL 150 and may vary depending on actual drilling requirements. PTFE slide bearings are recommended for pipe sizes above 10" NPS. FRP flanges require a full back-face. See page 25 for sizes 1" – 10". See page 26 for 12" – 30". See General Notes, pages 5 and 6.

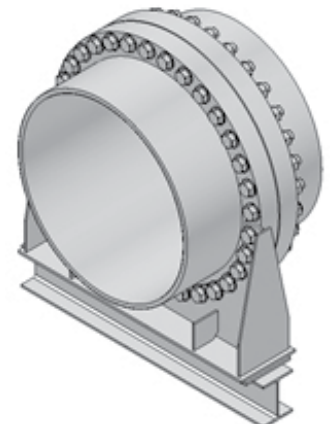

Pipe Size [in]	H [in]	L1 [in]	L2 [in]	W [in]	Allowable Loads [lb]
					Vertical
36	26 3/4	12	10	49 3/4	13000
42	30 1/4	14	12	56 3/4	18000
48	33 1/2	16	14	63 3/4	24000
54	38 1/2	18	16	72	30000
60	42	20	18	78 1/2	36000

Pipe Supports

Figure S13: Flange Slide
(1"-10" Diameter)

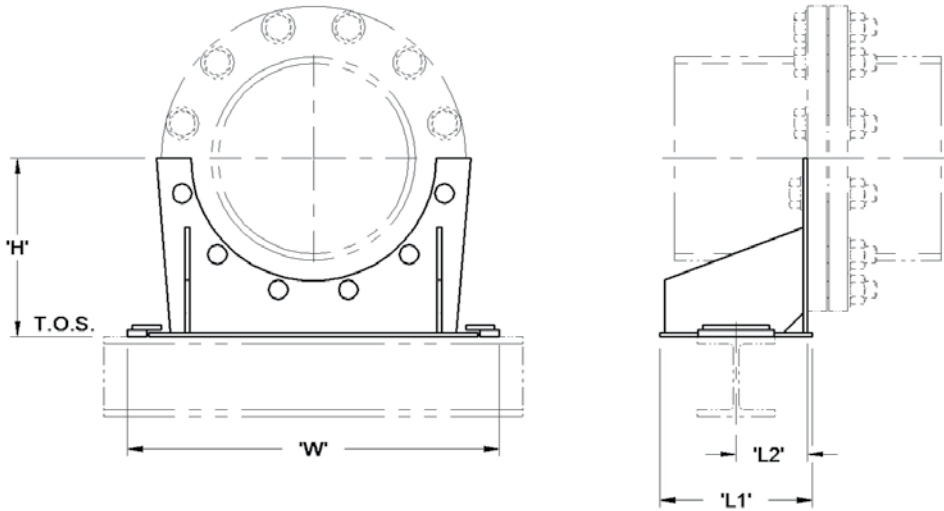

Finish:

Hot-dipped galvanized
See General Note 15, page 5.

Service:

To support weight of pipe, valves or equipment, while allowing freedom of axial movement and limiting lateral movement

Material:

Carbon steel
See General Note 14, page 5.

Notes:

Type FB1 welded guide clips are provided with this style of support. Type FB2 bolted guide clips are available upon request. Dimensions are based on ANSI B16.5 CL 150 flange drilling and may vary depending on actual drilling requirements. Can also be used as a flange riser guide. FRP flanges require a full back-face. See page 29 for sizes 12" – 30". See page 30 for sizes 36" – 60". See General Notes, pages 5 and 6.

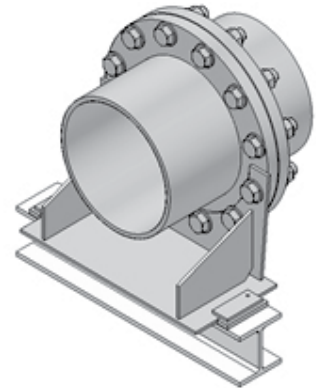

Pipe Size [in]	H [in]	L1 [in]	L2 [in]	W [in]	Allowable Loads [lb]	
					Lateral	Vertical
1	3 3/4	3	1 1/4	7 3/4	100	200
1 1/2	4 1/4	3	1 1/4	8 1/4	150	300
2	4 5/8	4	1 3/4	8 1/4	200	500
3	5 1/4	4	1 3/4	9 3/4	280	700
4	6	4	1 3/4	12 1/2	360	900
6	7	6	2 3/4	14 1/2	600	1500
8	8 1/4	6	2 3/4	16 1/2	720	1800
10	9 3/8	8	3 3/4	19 1/2	880	2200

Pipe Supports

Figure S13B: Flange Slide
(12"-30" Diameter)

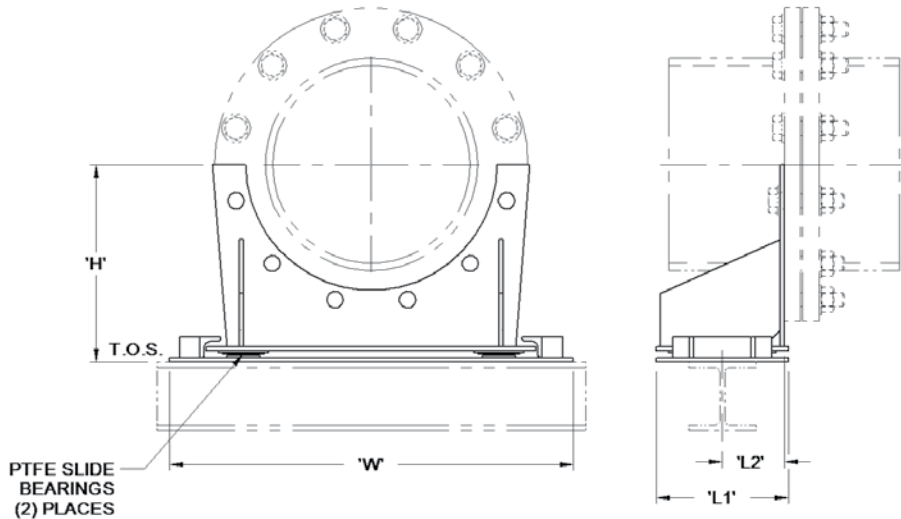

Finish:

Hot-dipped galvanized

See General Note 15, page 5.

Service:

To support weight of pipe, valves or equipment, while allowing freedom of axial movement and limiting lateral movement

Material:

Carbon steel

See General Note 14, page 5.

Notes:

Support is provided with a base plate for welded installations. Base plates for bolted installations are available upon request. Provide bolting arrangement with placement of order. Dimensions are based on ANSI B16.5 or ASME B16.47 Series A CL 150 flange drilling and may vary depending on actual drilling requirements. PTFE slide bearings are recommended for pipe sizes above 10" NPS. FRP flanges require a full back-face. See page 28 for sizes 1"-10". See page 30 for sizes 36" - 60". See General Notes, pages 5 and 6.

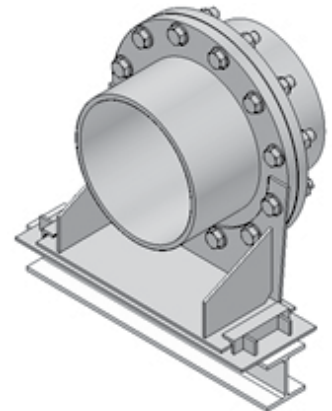

Pipe Size [in]	H [in]	L1 [in]	L2 [in]	W [in]	Allowable Loads [lb]	
					Lateral	Vertical
12	12	8	3 3/4	24 1/2	1120	2800
14	12 7/8	8	3 3/4	26	1280	3200
16	14 1/8	8	3 3/4	28	1680	4200
18	15 3/8	8	3 3/4	30 1/2	2100	5300
20	17 1/2	10	4 5/8	33 5/8	2600	6500
24	19 3/4	10	4 5/8	37 1/4	3600	8900
30	23 5/8	10	4 5/8	41 1/4	4400	11000

Pipe Supports

Figure S13B: Flange Slide
(36"-60" Diameter)

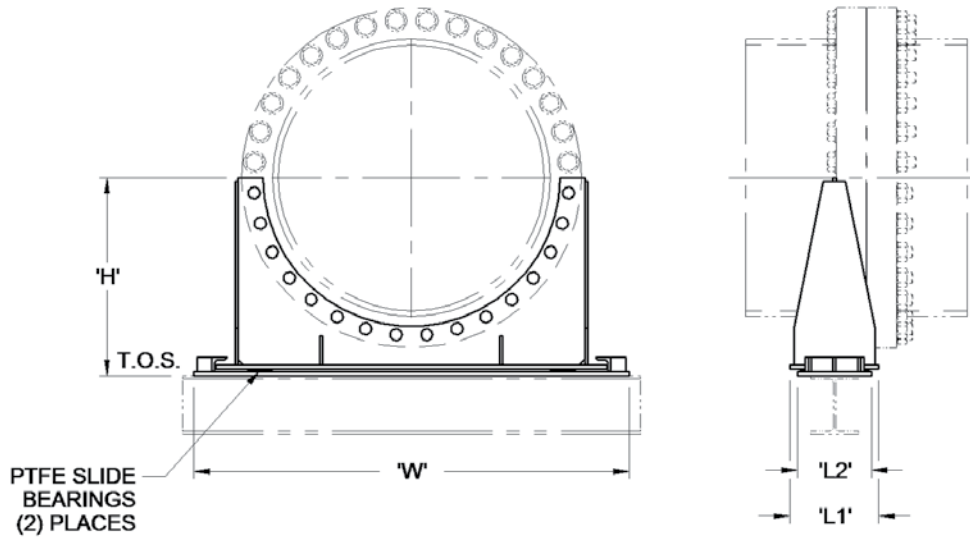

Finish:
Painted
See General Note 15, page 5.

Service:
To support weight of pipe, valves or equipment, while allowing freedom of axial movement and limiting lateral movement

Material:
Carbon steel
See General Note 14, page 5.

Notes:
Support is provided with a base plate for welded installations. Base plates for bolted installations are available upon request. Provide bolting arrangement with placement of order. Dimensions are based on ASME B16.47 Series A CL 150 flange drilling and may vary depending on actual drilling requirements. PTFE slide bearings are recommended for pipe sizes above 10" NPS. FRP flanges require a full back-face. See page 28 for sizes 1"-10". See page 29 for sizes 12" – 30". See General Notes, pages 5 and 6.

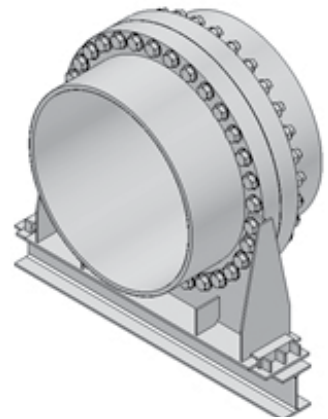

Pipe Size [in]	H [in]	L1 [in]	L2 [in]	W [in]	Allowable Loads [lb]	
					Lateral	Vertical
36	26 3/4	12	10	57 3/4	9100	13000
42	30 1/4	14	12	64 3/4	12600	18000
48	33 1/2	16	14	73 3/4	16800	24000
54	38 1/2	18	16	80 3/8	21000	30000
60	42	20	18	87	25000	36000

Pipe Supports

Figure S14: Flange Anchor

(1"-30" Diameter)

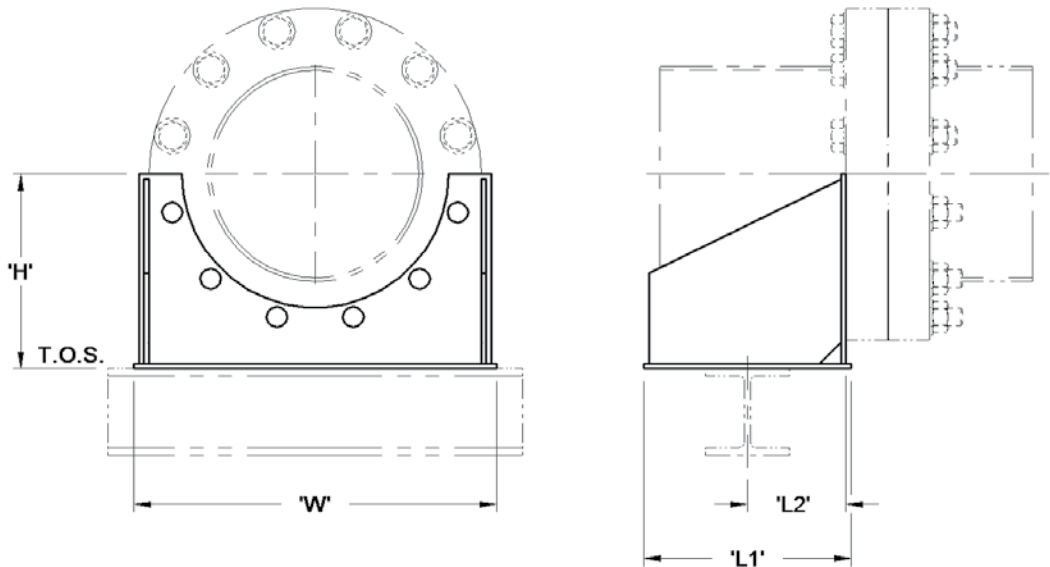

Finish:

Hot-dipped galvanized

See General Note 15, page 5.

Service:

To support weight of pipe, valves or equipment while restricting all movement

Material:

Carbon steel

See General Note 14, page 5.

Notes:

Support is provided with a base plate for welded installations. Base plates for bolted installations are available upon request. Provide bolting arrangement with placement of order. FRP flanges require a full back-face. Dimensions are based on ANSI B16.5 or ASME B16.47 Series A CL 150 flange drilling and may vary depending on actual drilling requirements. Can also be used as a flange riser anchor. See page 32 for sizes 36" – 60". See General Notes, pages 5 and 6.

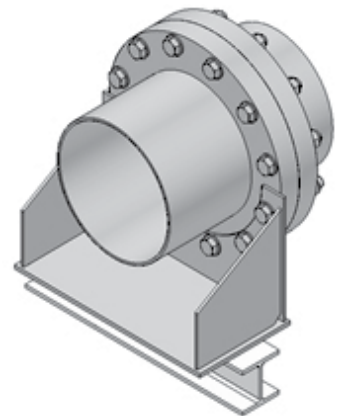

Pipe Size [in]	H [in]	L1 [in]	L2 [in]	W [in]	Allowable Loads [lb]		
					Lateral	Vertical	Axial
1	3 3/4	4	1 3/4	5 1/2	100	200	300
1 1/2	4 1/4	4	1 3/4	5 7/8	150	300	320
2	4 5/8	6	2 3/4	7 1/2	200	500	350
3	5 1/4	6	2 3/4	9	280	700	490
4	6	6	2 3/4	10 1/2	360	900	630
6	7	8	3 3/4	12 1/2	600	1500	1260
8	8 1/4	8	3 3/4	15	720	1800	1800
10	9 3/8	10	4 3/4	18	880	2200	2100
12	12	10	4 3/4	20 1/2	1120	2800	2400
14	12 7/8	10	4 3/4	22 1/2	1280	3200	3000
16	14 1/8	12	5 3/4	25 1/4	1680	4200	4200
18	15 3/8	12	5 5/8	26 7/8	2100	5300	5300
20	17 1/2	12	5 5/8	30 1/4	2600	6500	6500
24	19 3/4	12	5 5/8	34	3600	8900	7000
30	23 5/8	12	5 5/8	42	4400	11000	7500

Pipe Supports

Figure S14: Flange Anchor
(36"-60" Diameter)

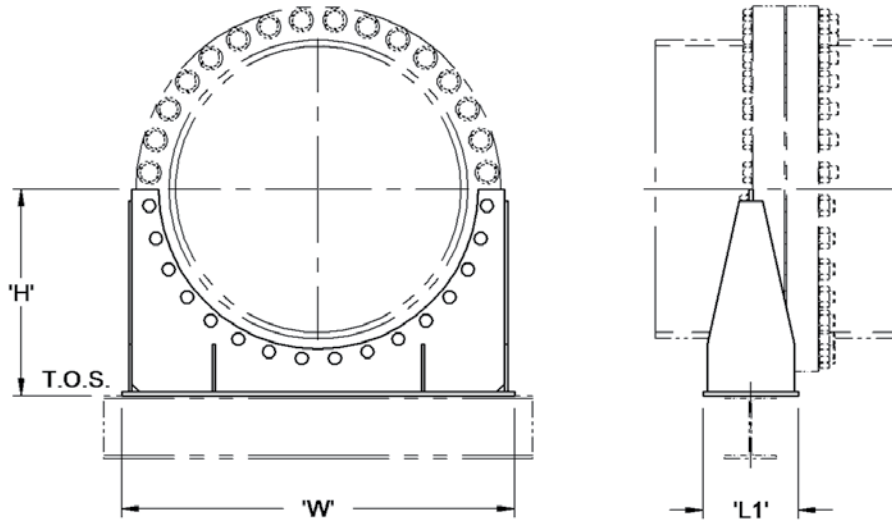

Finish:

Painted

See General Note 15, page 5.

Service:

To support weight of pipe, valves or equipment while restricting all movement

Material:

Carbon steel

See General Note 14, page 5.

Notes:

Support is provided with a base plate for welded installations. Base plates for bolted installations are available upon request. Provide bolting arrangement with placement of order. FRP flanges require a back-face. Dimensions are based on ASME B16.47 Series a CL 150 and may vary depending on actual drilling requirements. See page 31 for sizes 1" – 30". See General Notes, pages 5 and 6.

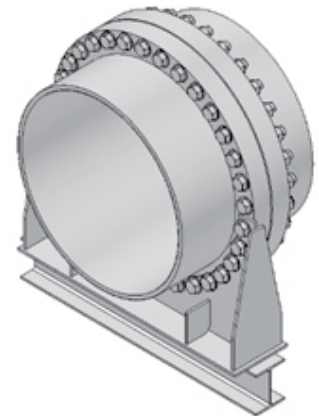

Pipe Size [in]	H [in]	L1 [in]	W [in]	Allowable Loads [lb]		
				Lateral	Vertical	Axial
36	26 3/4	12	49 3/4	9100	13000	8000
42	30 1/4	14	56 3/4	12600	18000	9100
48	33 1/2	16	63 3/4	16800	24000	12000
54	38 1/2	18	72	21000	30000	15000
60	42	20	78 1/2	25000	36000	18000

Pipe Supports

Figure S15: Flange Linestop

(1"-10" Diameter)

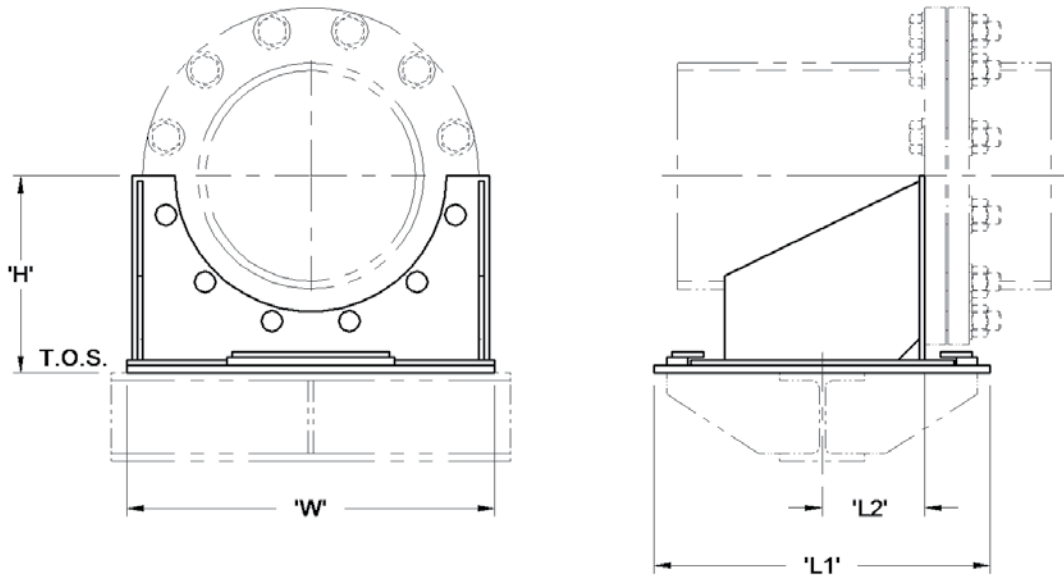

Finish:

Hot-dipped galvanized

See General Note 15, page 5.

Service:

To support weight of pipe, valves or equipment, while allowing freedom of lateral movement and limiting axial movement

Material:

Carbon steel

See General Note 14, page 5.

Notes:

If axial and lateral displacements are to be limited, request optional base plate type BP4, page 86. Base width (W) and length (L1) must be fully supported. Support is provided with a base plate for welded installations. Base plates for bolted installations are available upon request. Provide bolting arrangement with placement of order. FRP flanges require a full back-face. Dimensions are based on ANSI B16.5 CL 150 flange drilling and may vary depending on actual drilling requirements. See page 34 for sizes 12" – 30". See page 35 for sizes 36" – 60". See General Notes, pages 5 and 6.

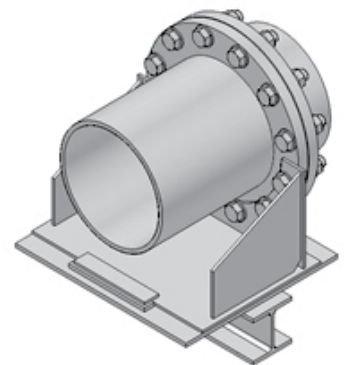

Pipe Size [in]	H [in]	L1 [in]	L2 [in]	W [in]	Allowable Loads [lb]	
					Vertical	Axial
1	3 3/4	8 1/4	1 3/4	5 1/2	200	300
1 1/2	4 1/4	8 1/4	1 3/4	5 7/8	300	320
2	4 5/8	10 1/2	2 3/4	7 1/2	500	350
3	5 1/4	10 1/2	2 3/4	9	700	490
4	6	10 1/2	2 3/4	10 1/2	900	630
6	7	14	3 3/4	12 1/2	1500	1260
8	8 1/4	14	3 3/4	15	1800	1800
10	9 3/8	16	4 3/4	18	2200	2100

Pipe Supports

Figure S15B: Flange Linestop
(12"-30" Diameter)

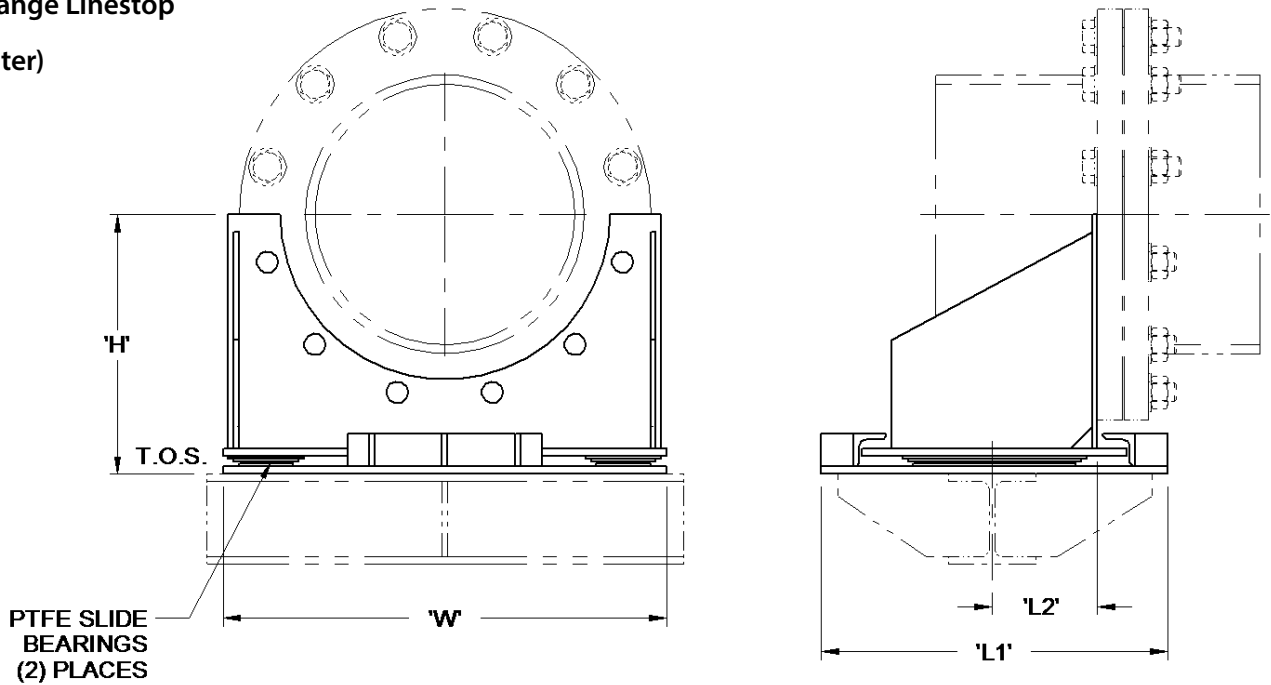

Finish:
Hot-dipped galvanized
See General Note 15, page 5.

Service:
To support weight of pipe, valves or equipment, while allowing freedom of lateral movement and limiting axial movement

Material:
Carbon steel
See General Note 14, page 5.

Notes:
If axial and lateral displacements are to be limited, request optional base plate type BP4, page 86. Base width (W) and length (L1) must be fully supported. Support is provided with a base plate for welded installation. Base plates for bolted installations are available upon request. Provide bolting arrangement with placement of order. FRP flanges require a full back-face. Dimensions are based on ANSI B16.5 or ASME B16.47 Series A CL 150 flange drilling and may vary depending on actual drilling requirements. PTFE slide bearings are recommended for pipe sizes above 10" NPS. See page 33 for sizes 1" – 10". See page 35 for sizes 36" – 60". See General Notes, pages 5 and 6.

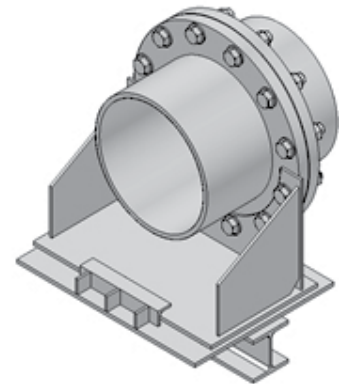

Pipe Size [in]	H [in]	L1 [in]	L2 [in]	W [in]	Allowable Loads [lb]	
					Vertical	Axial
12	12	16	4 3/4	20 1/2	2800	2400
14	12 7/8	16	4 3/4	22 1/2	3200	3000
16	14 1/8	18	5 3/4	25 1/4	4200	4200
18	15 3/8	18	5 5/8	26 7/8	5300	5300
20	17 1/2	18	5 5/8	30 1/4	6500	6500
24	19 3/4	18	5 5/8	34	8900	7000
30	23 5/8	18	5 5/8	42	11000	7500

Pipe Supports

Figure S15B: Flange Linestop
(36"-60" Diameter)

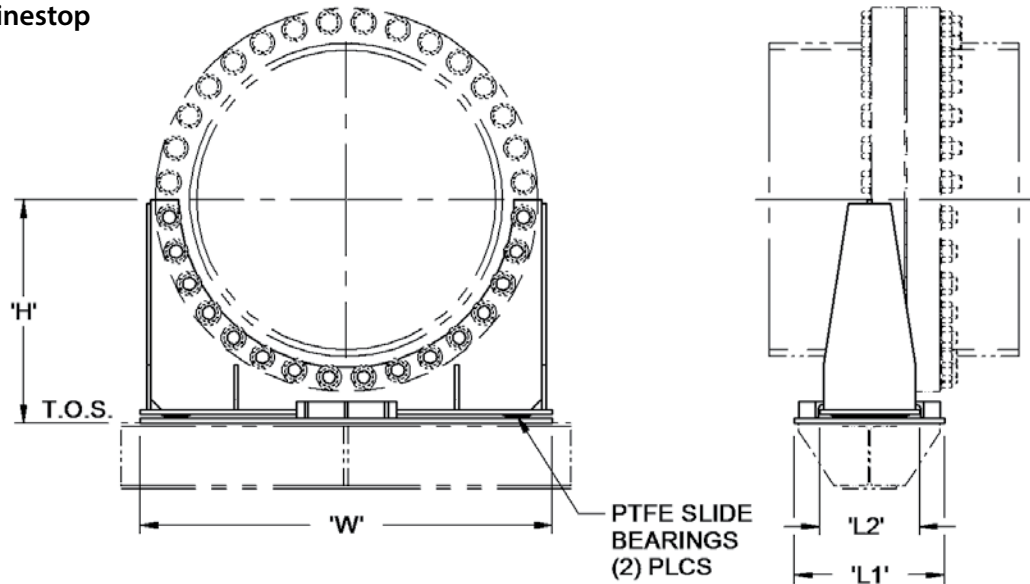

Finish:

Painted

See General Note 15, page 5.

Service:

To support weight of pipe, valves or equipment, while allowing freedom of lateral movement and limiting axial movement

Material:

Carbon steel

See General Note 14, page 5.

Notes:

If axial and lateral displacements are to be limited, request optional base plate type BP4, page 86. Base width (W) and length (L1) must be fully supported. Support is provided with a base plate for welded installation. Base plates for bolted installations are available upon request. Provide bolting arrangement with placement of order. FRP flanges require a full back-face. Dimensions are based on ASME B16.47 Series A CL 150 flange drilling and may vary depending on actual drilling requirements. PTFE slide bearings are recommended for pipe sizes above 10" NPS. See page 33 for sizes 1" – 10". See page 34 for sizes 12" – 30". See General Notes, pages 5 and 6.

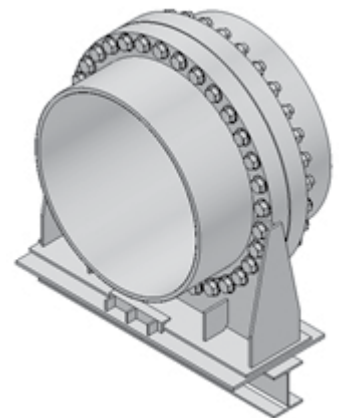

Pipe Size [in]	H [in]	L1 [in]	L2 [in]	W [in]	Allowable Loads [lb]	
					Vertical	Axial
36	26 3/4	21	15	49 3/4	13000	8000
42	30 1/4	23	17	56 3/4	18000	9100
48	33 1/2	25	19	63 3/4	24000	12000
54	38 1/2	27	21	72	30000	15000
60	42	29	23	78 1/2	36000	18000

Pipe Supports

Figure S16: Flange Hanger
(1"-18" Diameter)

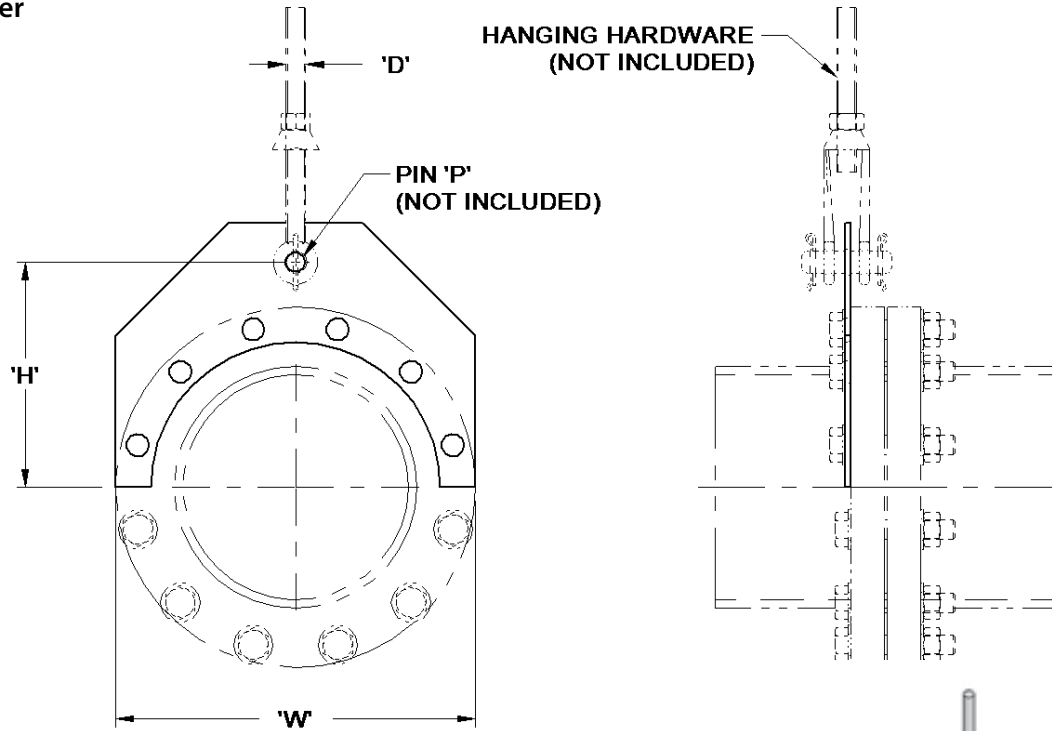

Finish:
Hot-dipped galvanized
See General Note 15, page 5.

Service:
To support weight of pipe, valves or equipment from above while allowing freedom of movement

Material:
Carbon steel

See General Note 14, page 5.

Notes:
Dimensions are based on ANSI B16.5 CL 150 flange drilling and may vary depending on actual drilling requirements. FRP flanges require full back-face. Hanging hardware is available upon request. See General Notes, pages 5 and 6.

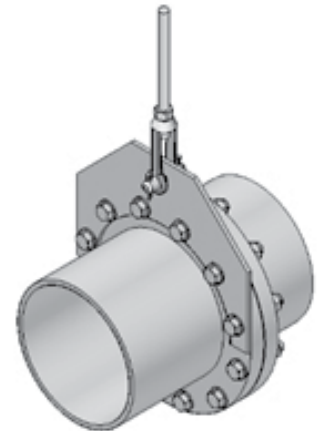

Pipe Size [in]	H [in]	D [in]	P [in]	W [in]	Allowable Loads [lb]
					Vertical
1	4 1/8	3/8	1/2	4 1/4	250
1 1/2	4 1/2	3/8	1/2	5	450
2	5	3/8	1/2	6	600
3	6	1/2	5/8	7 1/2	1100
4	6 1/2	5/8	3/4	9	1600
6	7 1/2	3/4	7/8	11	2200
8	9	3/4	7/8	14	2800
10	10	7/8	1	16	3200
12	12	7/8	1	19	3600
14	13	1	1 1/8	21	4000
16	14	1	1 1/8	24	4500
18	15	1	1 1/8	25	5300

Pipe Supports

Figure S17: Flange Riser Guide
(12"-30" Diameter)

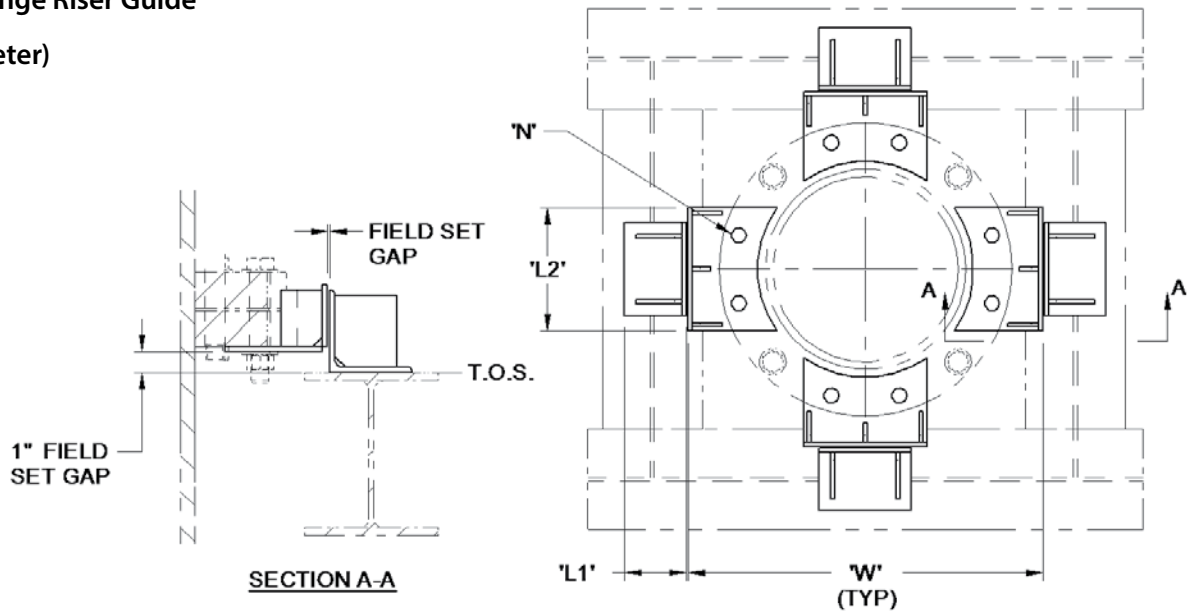

Finish:

Hot-dipped galvanized

See General Note 15, page 5.

Service:

To allow axial movement while limiting lateral movement

Material:

Carbon steel

See General Note 14, page 5.

Notes:

Not designed for vertical loading. Support width (W) is based on listed allowable loads. For a greater width, the support configuration may need to be adjusted to suit listed allowable loads. Type RGC1 welded riser guide clips are provided with this style of support. Type RGC2 bolted riser guide clips are available upon request, page 87. Dimensions are based on ANSI B16.5 or ASME B16.47 Series A CL 150 flange drilling and may vary depending on actual drilling requirements. FRP flanges require full back-face. See page 38 for sizes 36" – 60". See General Notes, pages 5 and 6.

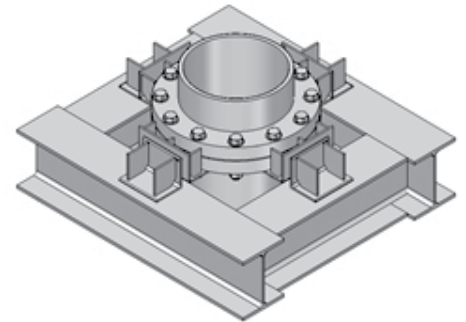

Pipe Size [in]	L1 [in]	L2 [in]	N # Of Holes	W [in]	Allowable Loads [lb]
					Lateral
12	4	8	8	23	3300
14	4	8 1/2	8	25	3600
16	4	15	16	27 1/2	4000
18	4	16	16	29	4400
20	4	15	16	31 1/2	5800
24	4	18	16	36	6600
30	4	16	16	44	8000

Pipe Supports

Figure S17: Flange Riser Guide
(36"-60" Diameter)

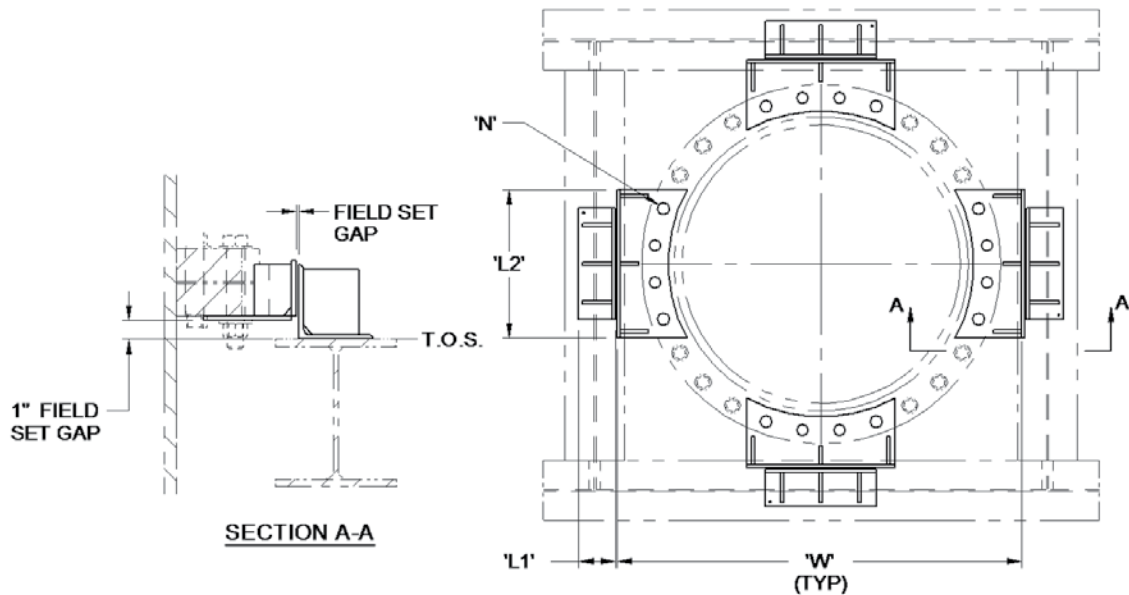

Finish:
Painted
See General Note 15, page 5.

Service:
To allow axial movement while limiting lateral movement

Material:
Carbon steel
See General Note 14, page 5.

Notes:
Not designed for vertical loading. Support width (W) is based on listed allowable loads. For a greater width, the support configuration may need to be adjusted to suit listed allowable loads. Type RGC1 welded riser guide clips are provided with this style of support. Type RGC2 bolted riser guide clips are available upon request, page 87. Dimensions are based on ASME B16.47 Series A CL 150 flange drilling and may vary depending on actual drilling requirements. FRP flanges require full back-face. See page 37 for sizes 12" – 30". See General Notes, pages 5 and 6.

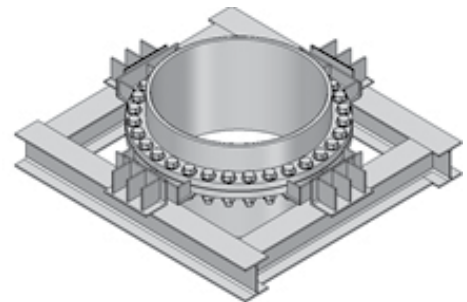

Pipe Size [in]	L1 [in]	L2 [in]	N # Of Holes	W [in]	Allowable Loads [lb]
					Lateral
36	6	17 1/2	16	53	9100
42	6	26 3/4	24	60	10500
48	6	24 1/2	24	66 1/2	12000
54	8	27 3/4	24	73 1/4	13500
60	8	34	32	80	15000

Pipe Supports

Figure S18: Flange Riser Support
(12"–60" Diameter)

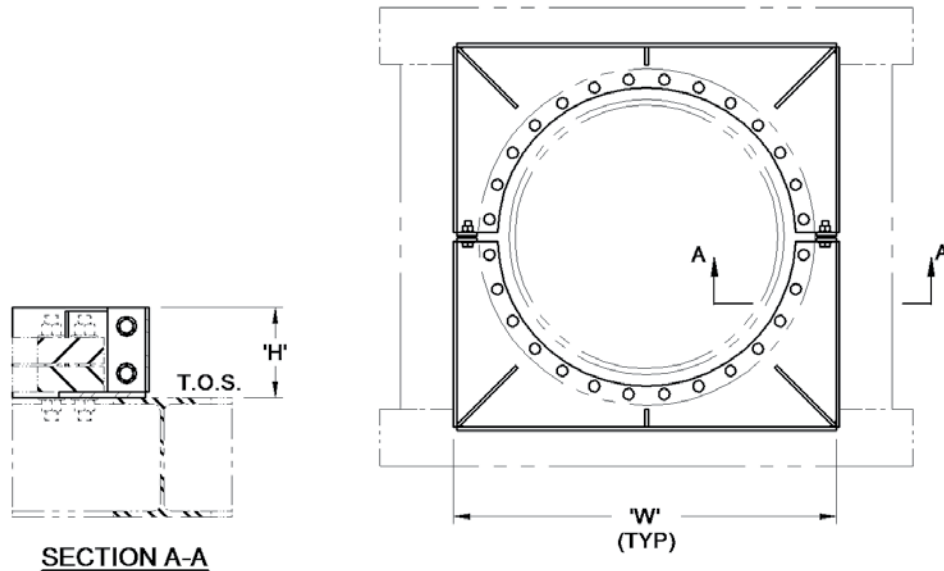

Finish:

12" – 30": Hot-dipped galvanized

36" – 60": Painted

See General Note 15, page 5.

Service:

To support weight of pipe while allowing freedom of lateral movement. May also be configured to restrict all movement

Material:

Carbon steel

See General Note 14, page 4.

Notes:

Support width (W) is based on listed allowable loads. For a greater width, the support configuration may need to be adjusted to suit listed allowable loads. If a fixed anchor type support is required, provide loads for evaluation. FRP flanges require a full back-face. Dimensions are based on ANSI B16.5 or ASME B16.47 Series A CL 150 flange drilling and may vary depending on actual drilling requirements. See General Notes, pages 5 and 6.

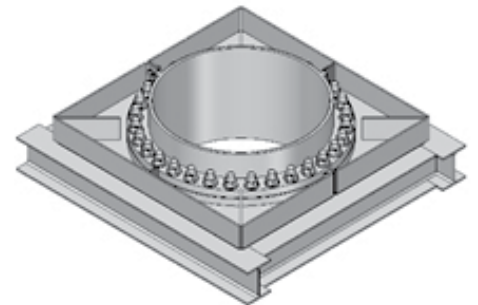

Pipe Size [in]	H [in]	W [in]	Allowable Loads [lb]
			Vertical
12	4	25	5800
14	4	27	6300
16	4	29 1/2	6900
18	4	31	7600
20	6	33 1/2	12000
24	6	38	15000
30	6	46 3/4	18000
36	6	54	24000
42	6	61	30000
48	8	67 1/2	36000
54	8	74 1/4	48000
60	8	81	60000

Pipe Supports

Figure S19: Flange Riser Support W/ Guides
(12"-60" Diameter)

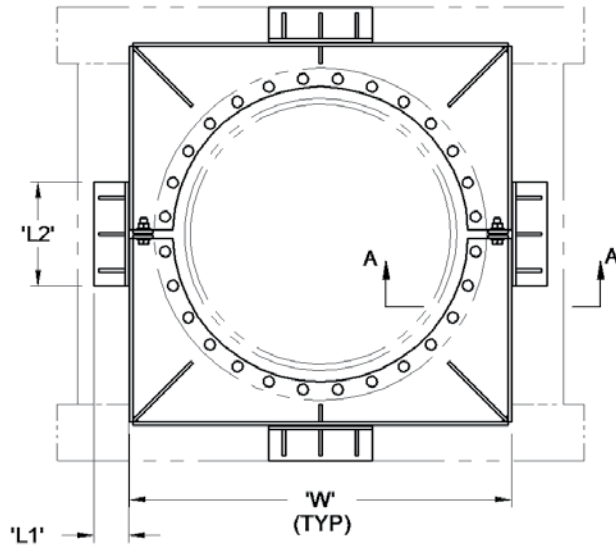
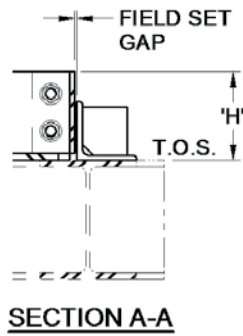

Finish:
12" – 30": Hot-dipped galvanized
36" – 60": Painted
See General Note 15, page 5.

Service:
To support weight of pipe while limiting lateral movement

Material:
Carbon steel
See General Note 14, page 5.

Notes:
Support width (W) is based on listed allowable loads. For a greater width, the support configuration may need to be adjusted to suit listed allowable loads. Type RC1 welded riser guide clips are provided with this style support. Type RGC2 bolted riser guide clips are available upon request, page 87. Dimensions are based on ANSI B16.5 or ASME B16.47 Series A CL 150 flange drilling and may vary depending on actual drilling requirements. FRP flanges require a full back-face. See General Notes, pages 5 and 6.

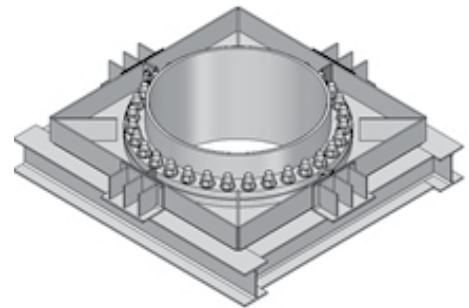

Pipe Size [in]	H [in]	L1 [in]	L2 [in]	W [in]	Allowable Loads [lb]	
					Lateral	Vertical
12	4	4	4	25	3300	5800
14	4	4	4	27	3600	6300
16	4	4	6	29 1/2	4000	6900
18	4	4	6	31	4400	7600
20	6	4	8	33 1/2	5800	12000
24	6	4	8	38	6600	15000
30	6	4	12	46 3/4	8000	18000
36	6	6	12	54	9100	24000
42	6	6	12	61	12600	30000
48	8	8	12	67 1/2	16800	36000
54	8	8	18	74 1/4	21000	48000
60	8	8	18	81	25000	60000

Pipe Supports

Figure P7: Elbow Support Slide Plate

(2"-10" Diameter)

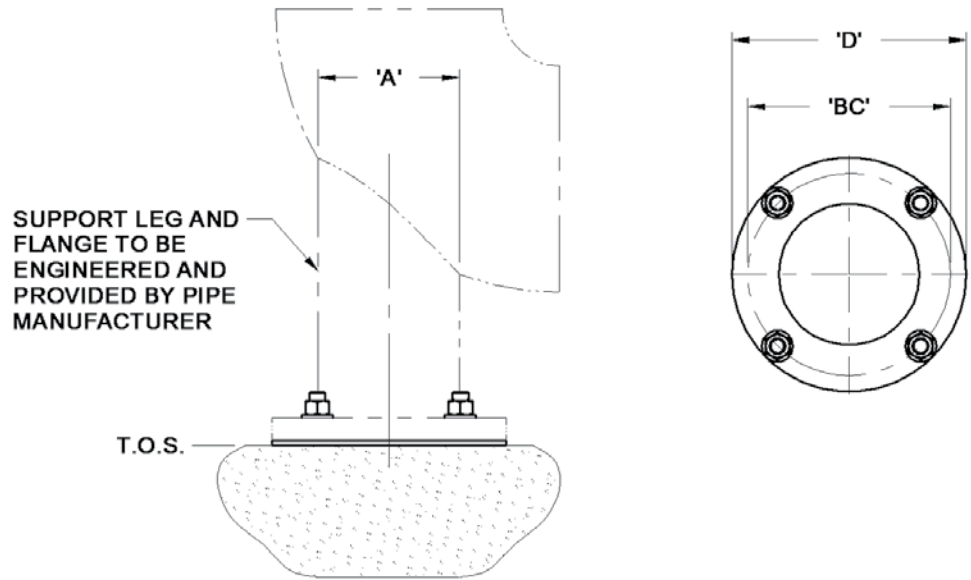

Finish:

Hot-dipped galvanized

See General Note 15, page 5.

Service:

To carry pipe weight while allowing freedom of movement

Material:

Carbon steel

See General Note 14, page 5.

Notes:

Bending moments should be evaluated at the connection to elbow. Provide support leg flange thickness when ordering. See General Notes, pages 5 and 6.

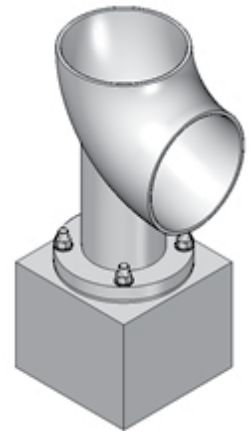

Elbow Size [in]	A [in]	BC [in]	D [in]
2	2	4 3/4	6
3	3	6	7 1/2
4	3	6	7 1/2
6	4	7 1/2	9
8	6	9 1/2	11
10	6	9 1/2	11

Pipe Supports

Figure P7B: Elbow Support Slide Plate
(12"-24" Diameter)

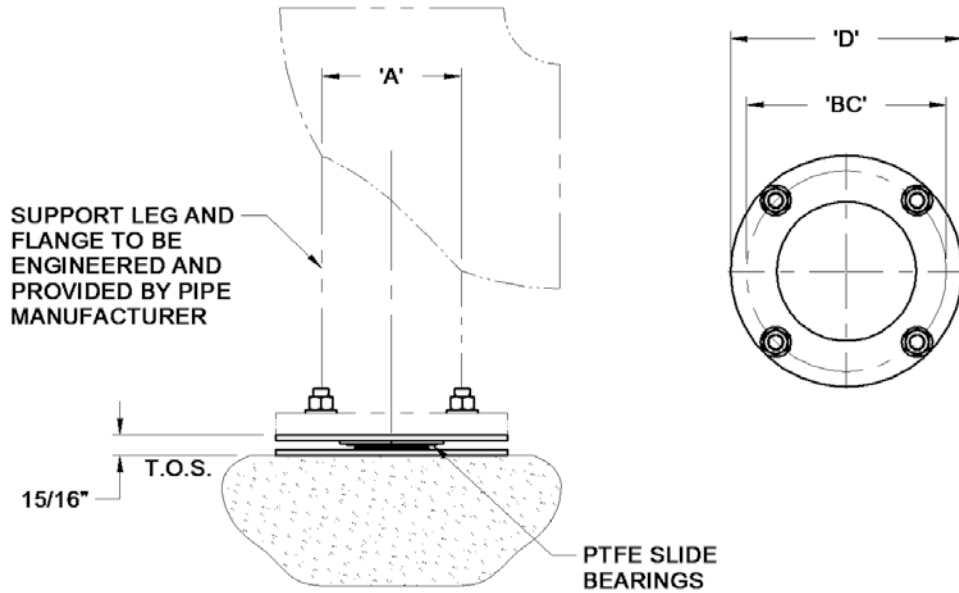

Finish:
Hot-dipped galvanized
See General Note 15, page 5.

Service:
To carry pipe weight while allowing freedom of movement

Material:
Carbon steel
See General Note 14, page 5.

Notes:
Bending moments should be evaluated at the connection to elbow. Provide support leg flange thickness when ordering. PTFE slide bearings are recommended for pipe sizes above 10" NPS. Support is provided with a base plate for welded installations. Base plates for bolted installations are available upon request. Provide bolting arrangement with placement of order. See General Notes, pages 5 and 6.

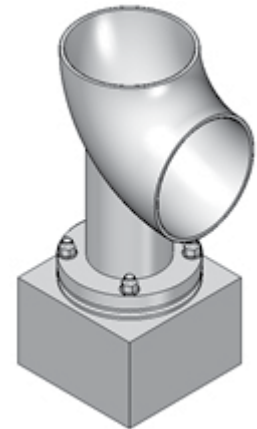

Elbow Size [in]	A [in]	BC [in]	D [in]
12	8	11 3/4	13 1/2
14	10	14 1/4	16
16	10	14 1/4	16
18	12	17	19
20	14	18 3/4	21
24	16	21 1/4	23 1/2

Pipe Supports

Figure P8: Base Slide
(1"-10" Diameter)

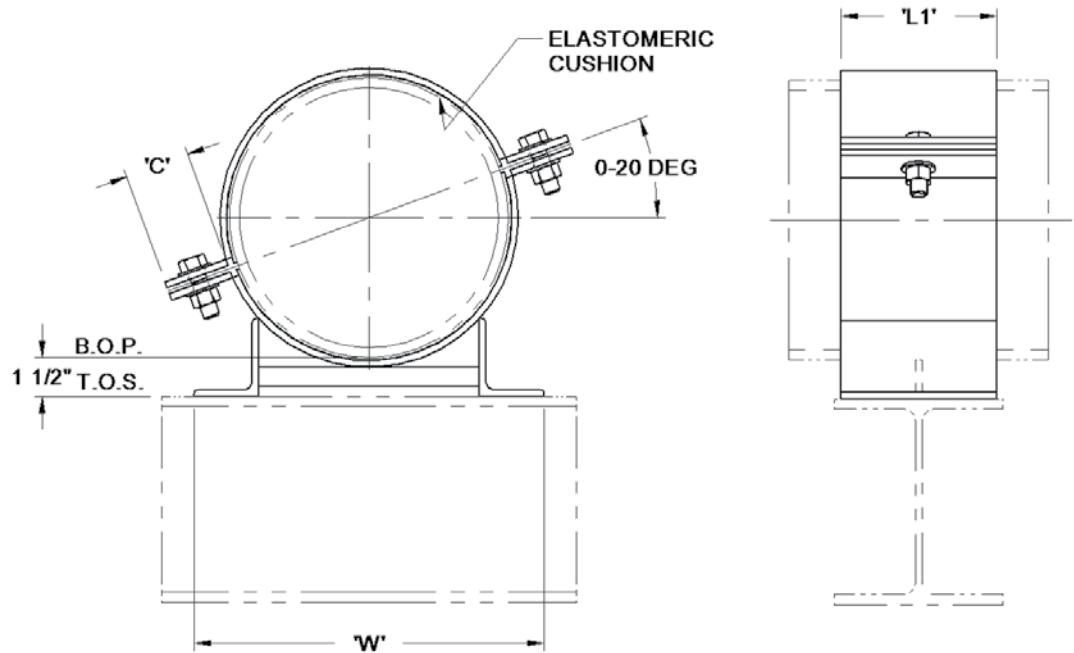

Finish:

Hot-dipped galvanized

See General Note 15, page 5.

Service:

To support weight of pipe while allowing freedom of movement

Material:

Carbon steel

See General Note 14, page 5.

Notes:

Dimensions are estimated based on typical 150 PSI rated pipe and may vary depending on the actual O.D. and load requirements. See General Notes, pages 5 and 6.

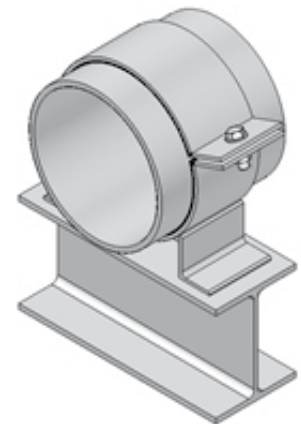

Pipe Size [in]	C [in]	L1 [in]	W [in]	Allowable Loads [lb]
				Vertical
1	1 1/2	3	4 3/8	150
1 1/2	1 1/2	3	4 1/2	200
2	1 1/2	3	4 3/4	300
3	1 1/2	3	6 1/4	430
4	1 1/2	3	6 1/2	550
6	2	4	8 7/8	1090
8	2	4	10 3/4	1440
10	2 1/2	5	13 1/2	2000

Pipe Supports

Figure P8L: Base Slide - Low Profile
(1"-10" Diameter)

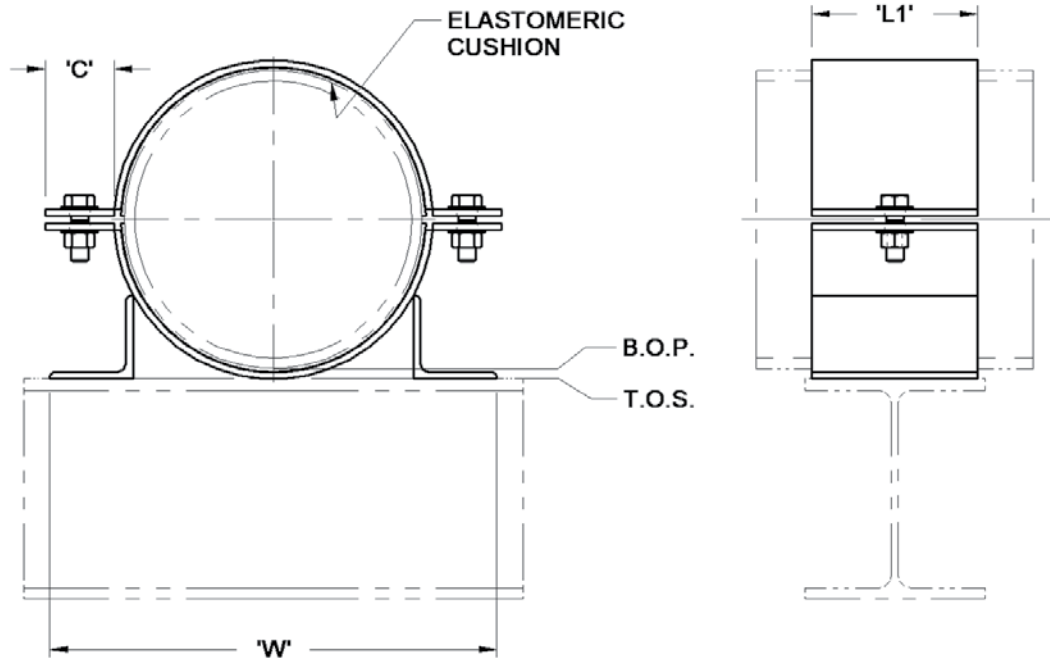

Finish:
Hot-dipped galvanized
See General Note 15, page 5.

Service:
To support weight of pipe while allowing freedom of movement

Material:
Carbon steel
See General Note 14, page 5.

Notes:
Base width (W) must be fully supported as shown. Lower saddle rests on supporting structure. Dimensions are estimated based on typical 150 PSI rated pipe and may vary depending on the actual O.D. and load requirements. See General Notes, pages 5 and 6.

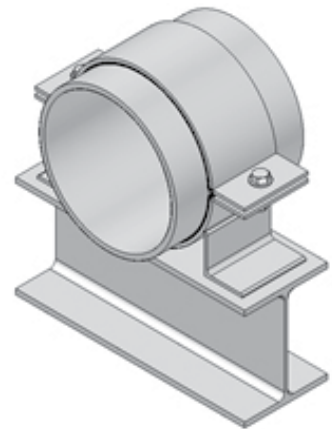

Pipe Size [in]	C [in]	L1 [in]	W [in]	Allowable Loads [lb]
				Vertical
1	1 1/2	3	4 3/8	150
1 1/2	1 1/2	3	4 1/2	200
2	1 1/2	3	5 3/4	300
3	1 1/2	3	6 1/4	430
4	1 1/2	3	7 5/8	530
6	2	4	10 5/8	1090
8	2	4	11 3/4	1440
10	2 1/2	5	16 1/8	2000

Pipe Supports

Figure P9: Base Guide
(1"-10" Diameter)

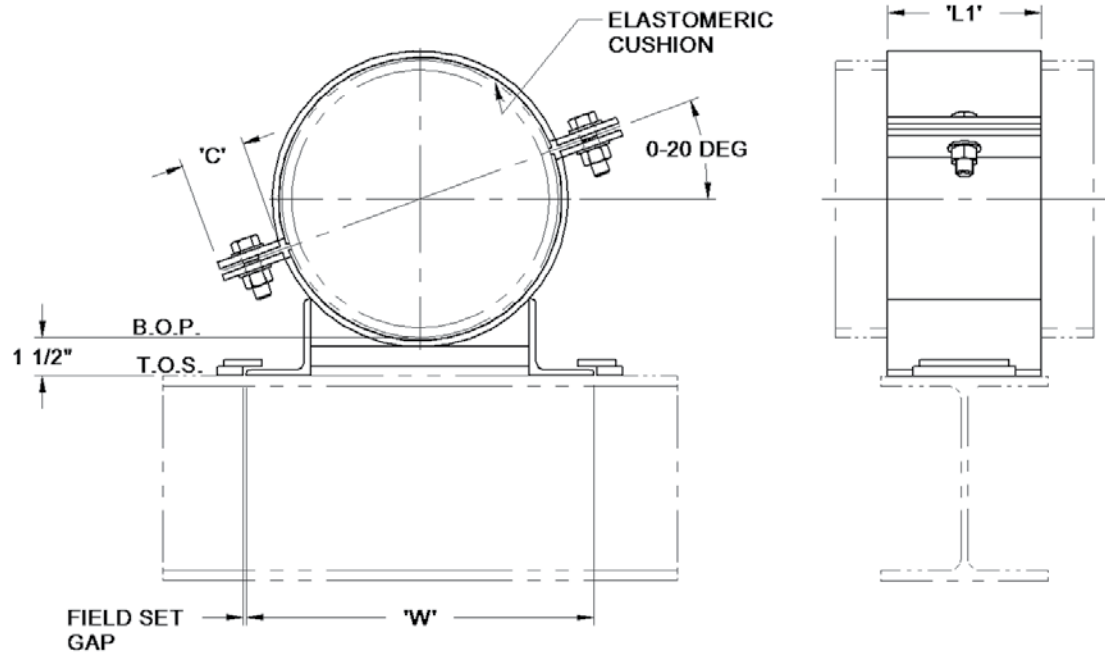

Finish:

Hot-dipped galvanized

See General Note 15, page 5.

Service:

To support weight of pipe while allowing freedom of axial movement and limiting lateral movement

Material:

Carbon steel

See General Note 14, page 5.

Notes:

Type FB1 welded guide clips are provided with this style of support. Type FB2 bolted guide clips are available upon request, page 87. Dimensions are based on typical 150 PSI rated pipe and may vary depending on the actual O.D. and load requirements. See General Notes, pages 5 and 6.

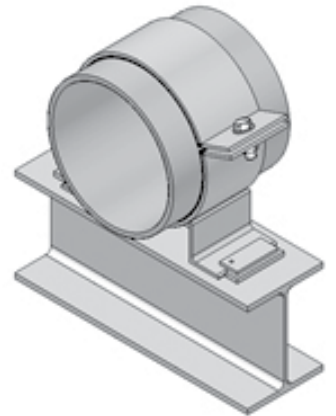

Pipe Size [in]	C [in]	L1 [in]	W [in]	Allowable Loads [lb]	
				Lateral	Vertical
1	1 1/2	3	4 3/8	80	150
1 1/2	1 1/2	3	4 1/2	100	200
2	1 1/2	3	4 3/4	130	270
3	1 1/2	3	6 1/4	190	380
4	1 1/2	3	6 1/2	240	500
6	2	4	8 7/8	480	980
8	2	4	10 3/4	650	1280
10	2 1/2	5	13 1/2	800	2000

Pipe Supports

Figure P9L: Base Guide - Low Profile
(1"-10" Diameter)

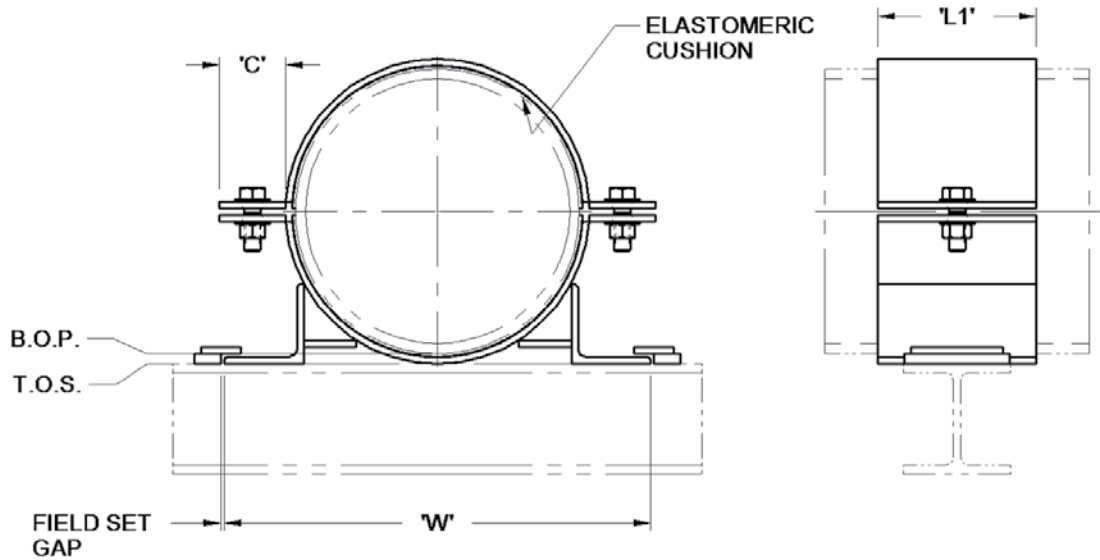

Finish:

Hot-dipped galvanized

See General Note 15, page 5.

Service:

To support weight of pipe while allowing freedom of axial movement and limiting lateral movement

Material:

Carbon steel

See General Note 14, page 5.

Notes:

Base width (W) must be fully supported as shown. Lower saddle rests on supporting structure. Type FB1 welded guide clips are provided with this style of support. Type FB2 bolted guide clips are available upon request, page 87. Dimensions are based on typical 150 PSI rated pipe and may vary depending on the actual O.D. and load requirements. See General Notes, pages 5 and 6.

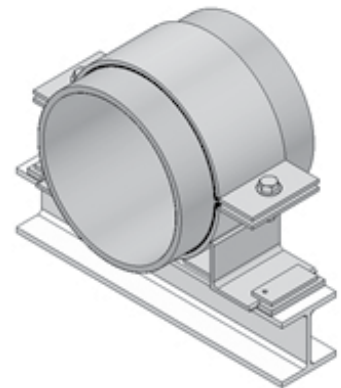

Pipe Size [in]	C [in]	L1 [in]	W [in]	Allowable Loads [lb]	
				Lateral	Vertical
1	1 1/2	3	5 3/8	80	150
1 1/2	1 1/2	3	4 1/2	100	200
2	1 1/2	3	6 3/4	130	270
3	1 1/2	3	6 1/4	190	380
4	1 1/2	3	7 5/8	240	500
6	2	4	10 5/8	480	980
8	2	4	11 3/4	650	1280
10	2 1/2	5	16 1/8	800	2000

Pipe Supports

Figure P10: Base Anchor

(1"-10" Diameter)

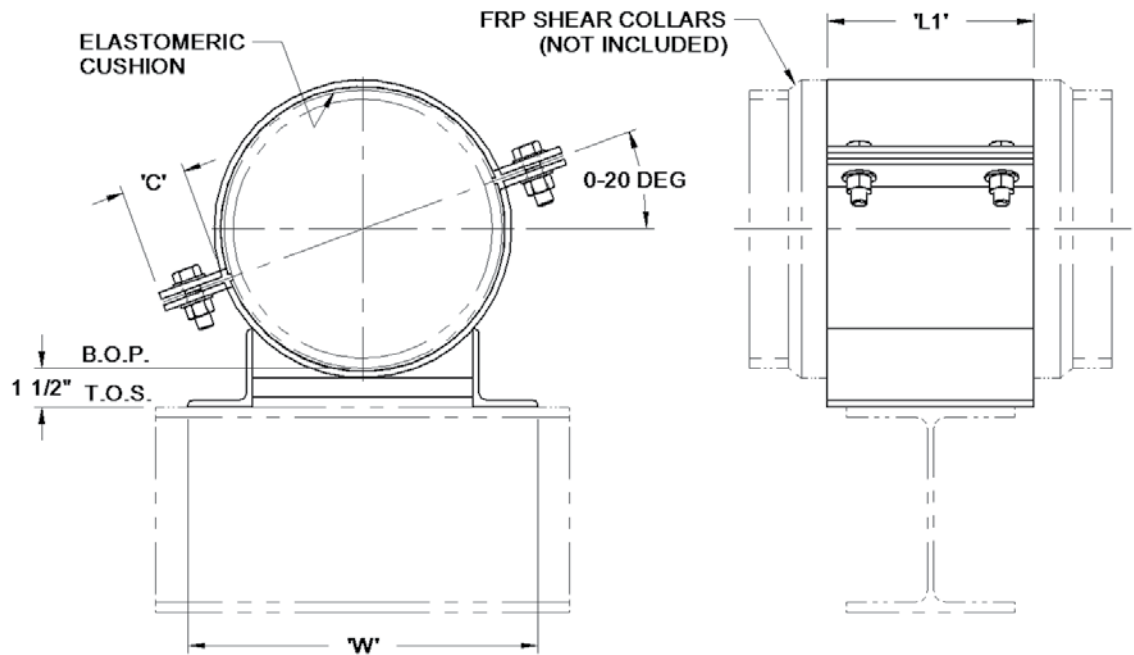

Finish:

Hot-dipped galvanized

See General Note 15, page 5.

Service:

To support weight of pipe while restricting all movement

Material:

Carbon steel

See General Note 14, page 5.

Notes:

Support is provided with a base sized for a welded installation. A bolted installation is available upon request. Provide bolting arrangement with placement of order. If limiting axial displacement is required, request linstop clips type LS1 or LS2 with placement of order. Dimensions are based on typical 150 PSI rated pipe and may vary depending on the actual O.D. and load requirements. See General Notes, pages 5 and 6.

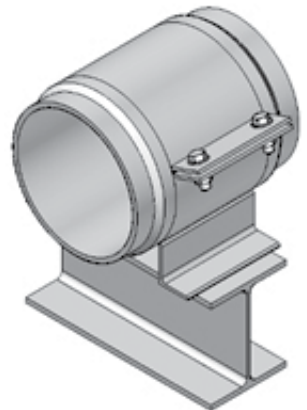

Pipe Size [in]	C [in]	L1 [in]	W [in]	Allowable Loads [lb]		
				Lateral	Vertical	Axial
1	1 1/2	3	4 3/8	80	150	350
1 1/2	1 1/2	3	4 1/2	100	200	450
2	1 1/2	3	4 3/4	130	270	650
3	1 1/2	3	6 1/4	190	380	800
4	1 1/2	4	6 1/2	340	660	1200
6	2	6	8 7/8	800	1400	2700
8	2	8	10 3/4	1100	2600	4200
10	2 1/2	8	13 1/2	1200	3300	5000

Pipe Supports

Figure P10L: Base Anchor - Low Profile

(1"-10" Diameter)

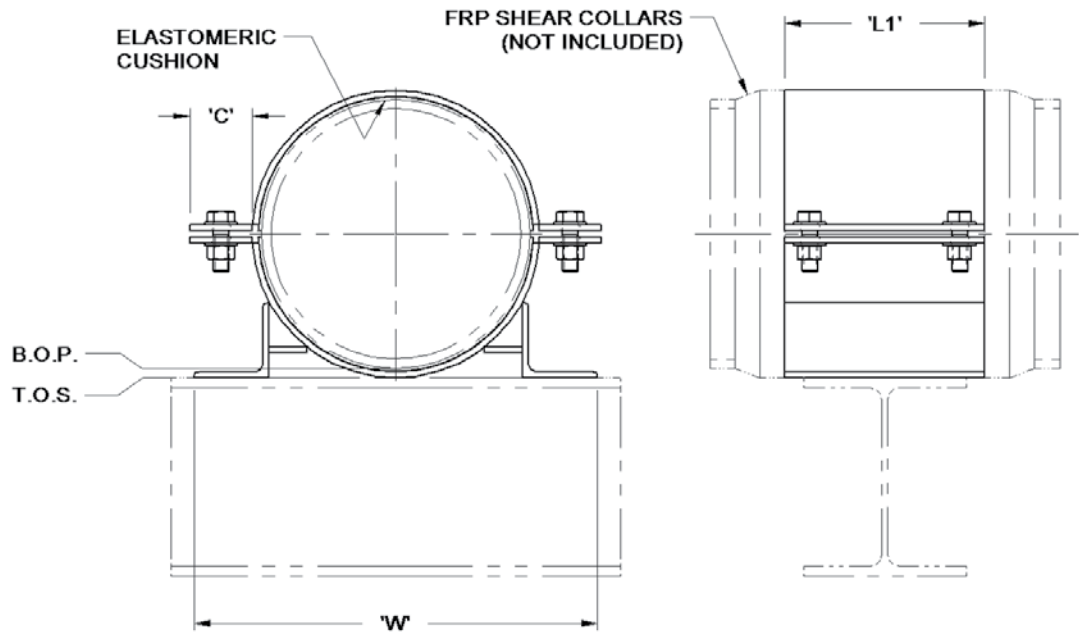

Finish:

Hot-dipped galvanized

See General Note 15, page 5.

Service:

To support weight of pipe while restricting all movement

Material:

Carbon steel

See General Note 14, page 5.

Notes:

Base width (W) must be fully supported as shown. Lower saddle rests on supporting structure. Support is provided with a base sized for a welded installation. A bolted installation is available upon request. Provide bolting arrangement with placement of order. If limiting axial displacement is required, request linestop clips type LS1 or LS2 with placement of order. Dimensions are based on typical 150 PSI rated pipe and may vary depending on the actual O.D. and load requirements. See General Notes, pages 5 and 6.

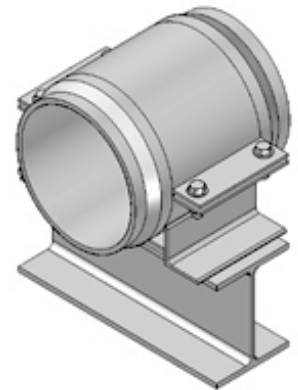

Pipe Size [in]	C [in]	L1 [in]	W [in]	Allowable Loads [lb]		
				Lateral	Vertical	Axial
1	1 1/2	3	4 3/8	80	150	350
1 1/2	1 1/2	3	4 1/2	100	200	450
2	1 1/2	3	5 3/4	130	270	650
3	1 1/2	3	6 1/4	190	380	800
4	1 1/2	4	7 5/8	340	660	1200
6	2	6	10 5/8	800	1400	2700
8	2	8	11 3/4	1100	2600	4200
10	2 1/2	8	16 1/8	1200	3300	5000

Pipe Supports

Figure P13: Riser Guide

(1"-20" Diameter)

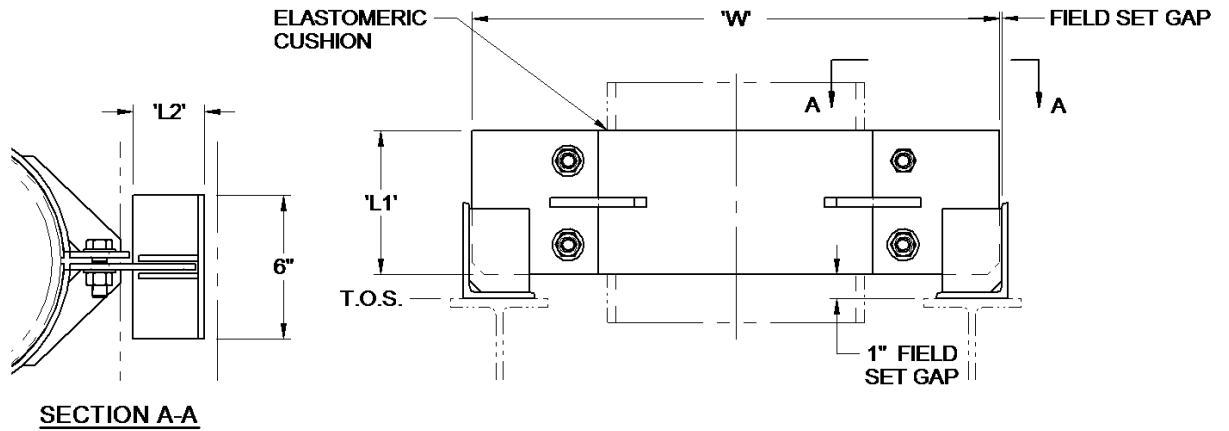

Finish:

Hot-dipped galvanized

See General Note 15, page 5.

Service:

To allow axial movement while limiting lateral movement

Material:

Carbon steel

See General Note 14, page 5.

Notes:

Not designed for vertical loads. Type RGC1 welded riser guide clips are provided with this style of support. Type RGC2 bolted riser guide clips are available upon request, page 87. Dimensions are based on typical 150 PSI rated pipe and may vary depending on the actual O.D. and load requirements. See page 50 for sizes 24" – 60". See General Notes, page 3 and 4.

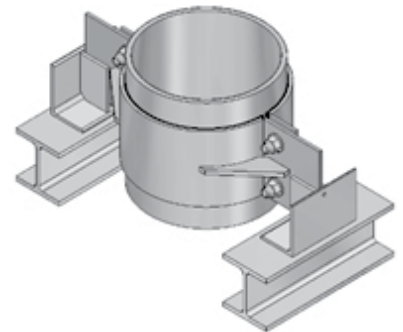

Pipe Size [in]	L1[in]	L2 [in]	W [in]	Allowable Loads [lb]
				Lateral
1	3	2	10 1/4	80
1 1/2	3	2	10 3/4	100
2	3	2	11 1/4	130
3	3	2	12 1/4	190
4	3	2	13 1/4	240
6	4	2	15 3/4	360
8	4	2	17 3/4	480
10	6	3	22	650
12	6	3	24 3/4	900
14	8	4	27	1500
16	8	4	29 1/2	1700
18	10	4	31 1/2	2300
20	10	4	34	2700

Pipe Supports

Figure P13: Riser Guide
(24"-60" Diameter)

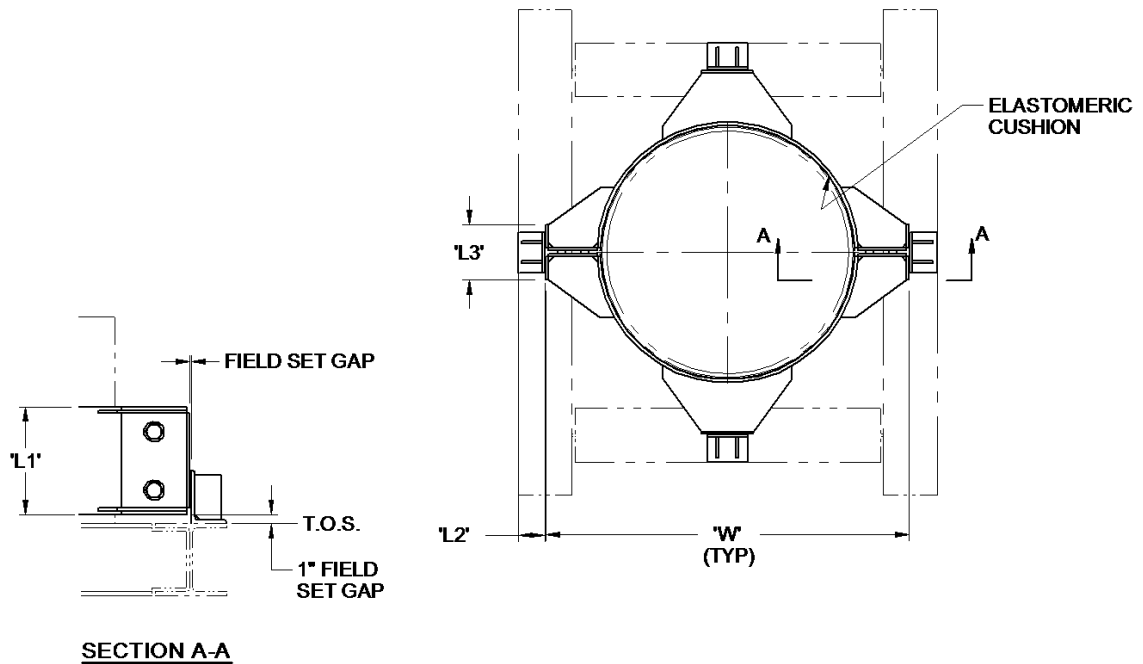

Finish:

Painted

See General Note 15, page 5.

Service:

To allow axial movement while limiting lateral movement

Material:

Carbon steel

See General Note 14, page 5.

Notes:

Not designed for vertical loads. Type RGC1 welded riser clips are provided with this style support. Type RGC2 bolted riser clips are available upon request, page 87. Dimensions are based on typical 150 PSI rated pipe and may vary depending on the actual O.D. and load requirements. See page 49 for sizes 1" – 20". See General Notes, pages 5 and 6.

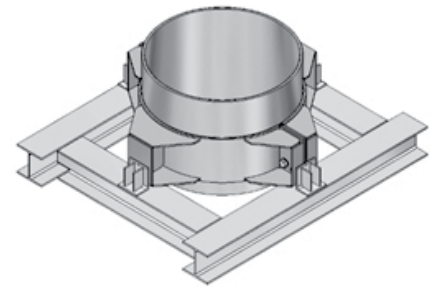

Pipe Size [in]	L1 [in]	L2 [in]	L3 [in]	W [in]	Allowable Loads [lb]
					Lateral
24	8	4	6	38	6000
30	10	6	6	44 1/2	9100
36	12	6	8	54 1/2	13000
42	14	6	10	61 3/8	17000
48	16	6	10	67 7/8	23000
54	18	8	12	73 3/4	29000
60	20	8	12	80	35000

Pipe Supports

Figure P14: Riser Support

(1"-10" Diameter)

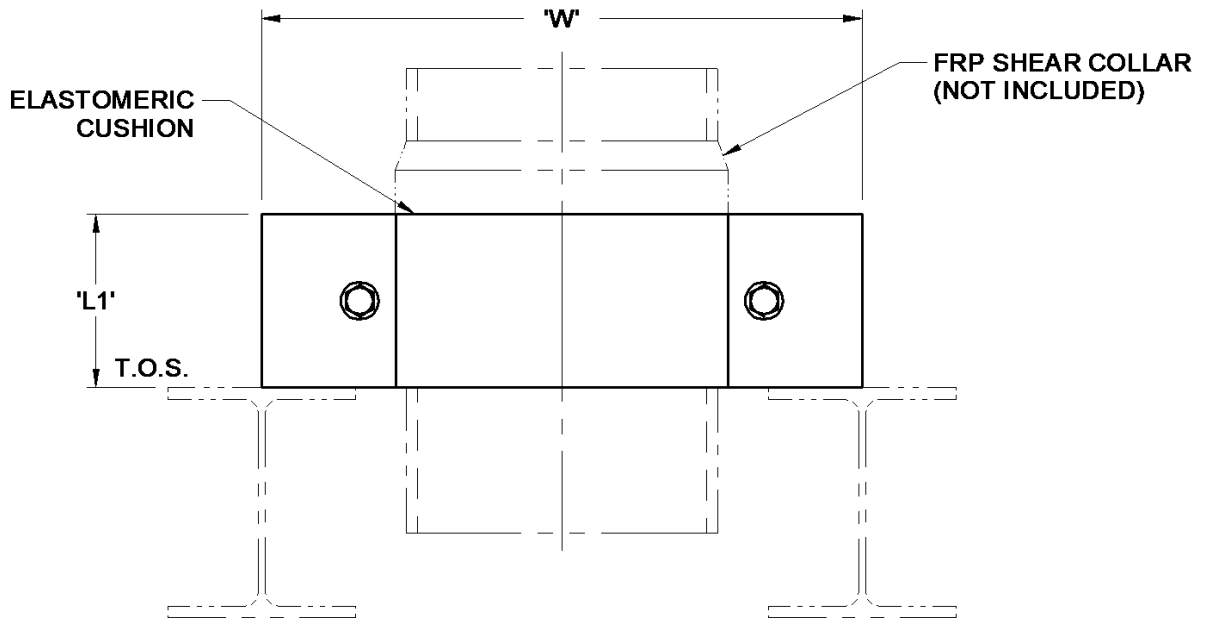

Finish:

Hot-dipped galvanized

See General Note 15, page 5.

Service:

To support weight of pipe while allowing freedom of lateral movement

Material:

Carbon steel

See General Note 14, page 5.

Notes:

Not designed for lateral loading. Support width (W) is based on listed available loads. For a greater width, the support configuration may need to be adjusted to suit listed available loads. If a fixed anchor type support is required, provide loads for evaluation. Dimensions are based on typical 150 PSI rated pipe and may vary depending on the actual O.D. and load requirements. See page 52 for sizes 12" – 30". See page 53 for sizes 36" – 60". See General Notes, pages 5 and 6.

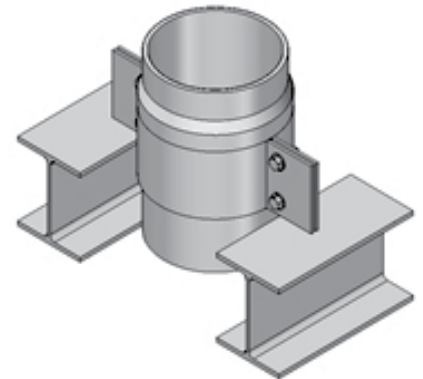

Pipe Size [in]	L1 [in]	W [in]	Allowable Loads [lb]
			Vertical
1	3	10 1/4	400
1 1/2	3	10 3/4	550
2	3	11 1/4	700
3	3	12 1/4	850
4	3	13 1/4	1200
6	4	15 3/4	1600
8	4	17 3/4	2000
10	6	20 3/4	2800

Pipe Supports

Figure P14: Riser Support
(12"-30" Diameter)

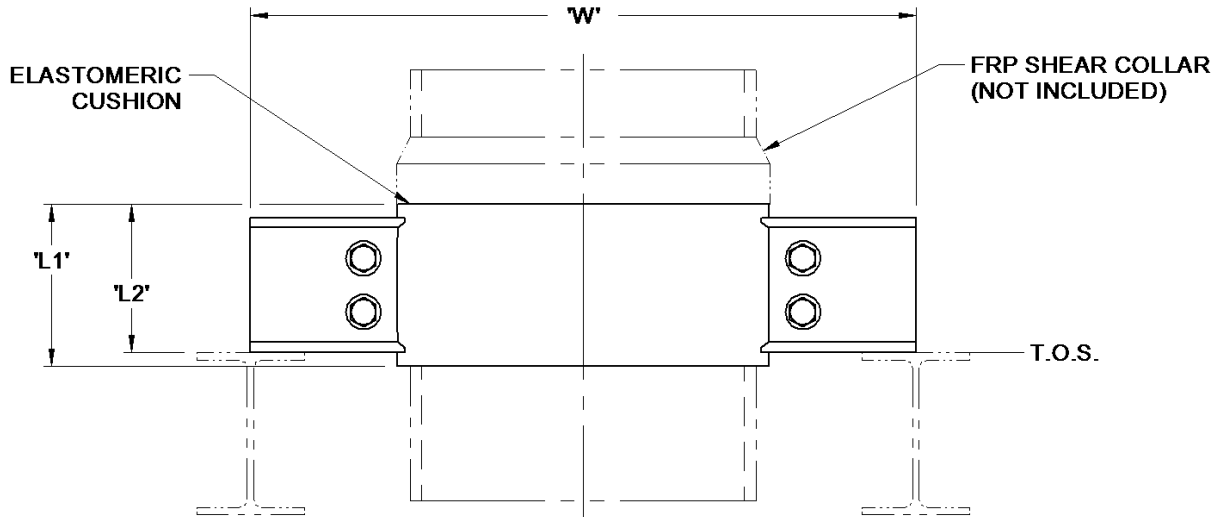

Finish:

Hot-dipped galvanized

See General Note 15, page 5.

Service:

To support weight of pipe while allowing freedom of lateral movement

Material:

Carbon steel

See General Note 14, page 5.

Notes:

Not designed for lateral loading. Support width (W) is based on listed available loads. For a greater width, the support configuration may need to be adjusted to suit listed available loads. If a fixed anchor type support is required, provide loads for evaluation. Dimensions are based on typical 150 PSI rated pipe and may vary depending on the actual O.D. and load requirements. See page 51 for sizes 1" – 10". See page 53 for sizes 36" – 60". See General Notes, pages 5 and 6.

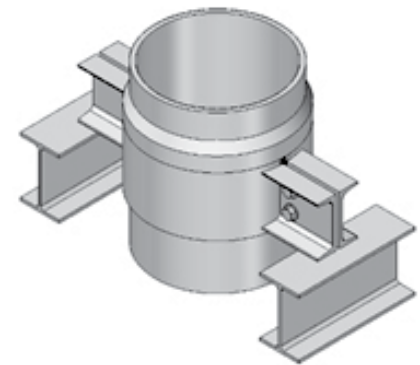

Pipe Size [in]	L1 [in]	L2 [in]	W [in]	Allowable Loads [lb]
				Vertical
12	6	5 1/2	24 3/4	3200
14	8	7 1/2	27	4000
16	9	8 1/2	29 1/2	4800
18	10	9 1/2	31 1/2	5900
20	12	11	34	7700
24	12	11	38	9500
30	12	11	44 1/2	13500

Pipe Supports

Figure P14: Riser Support
(36"-60" Diameter)

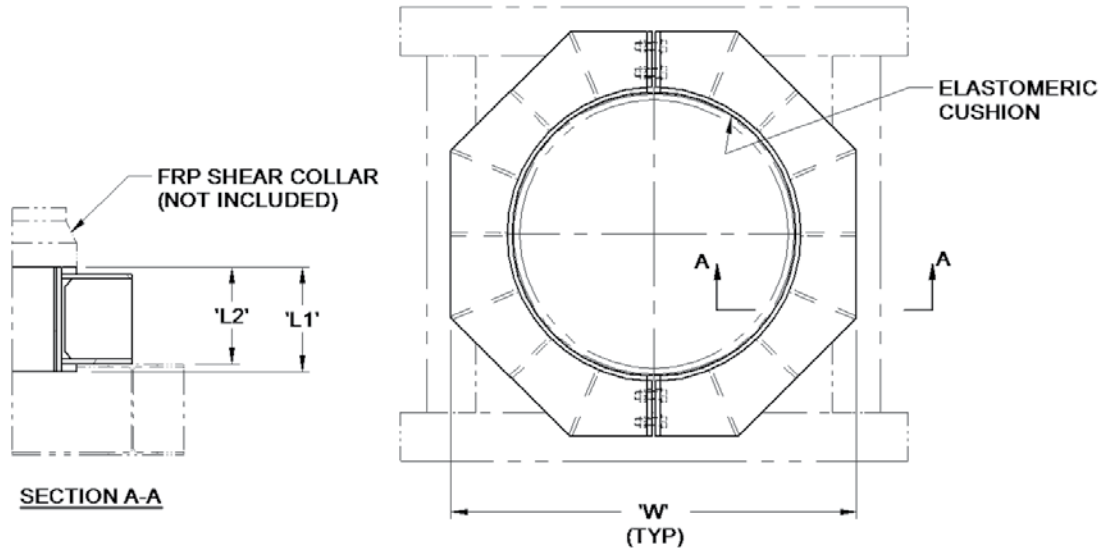

Finish:

Painted

See General Note 15, page 5.

Service:

To support weight of pipe while allowing freedom of lateral movement

Material:

Carbon steel

See General Note 14, page 5.

Notes:

Not designed for lateral loading. Support width (W) is based on listed available loads. For a greater width, the support configuration may need to be adjusted to suit listed available loads. If a fixed anchor type support is required, provide loads for evaluation. Dimensions are based on typical 150 PSI rated pipe and may vary depending on the actual O.D. and load requirements. See page 51 for sizes 1" – 10". See page 52 for sizes 12" – 30". See General Notes, pages 5 and 6.

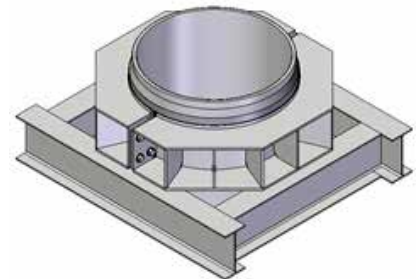

Pipe Size [in]	L1 [in]	L2 [in]	W [in]	Allowable Loads [lb]	
				Lateral	Vertical
36	12	11	53	13000	32000
42	14	13	60	17000	45000
48	16	15	66 1/2	23000	58000
54	18	17	73 3/4	29000	72000
60	20	19	80	35000	85000

Pipe Supports

Figure P15: Double Rod Riser Hanger
(1"-10" Diameter)

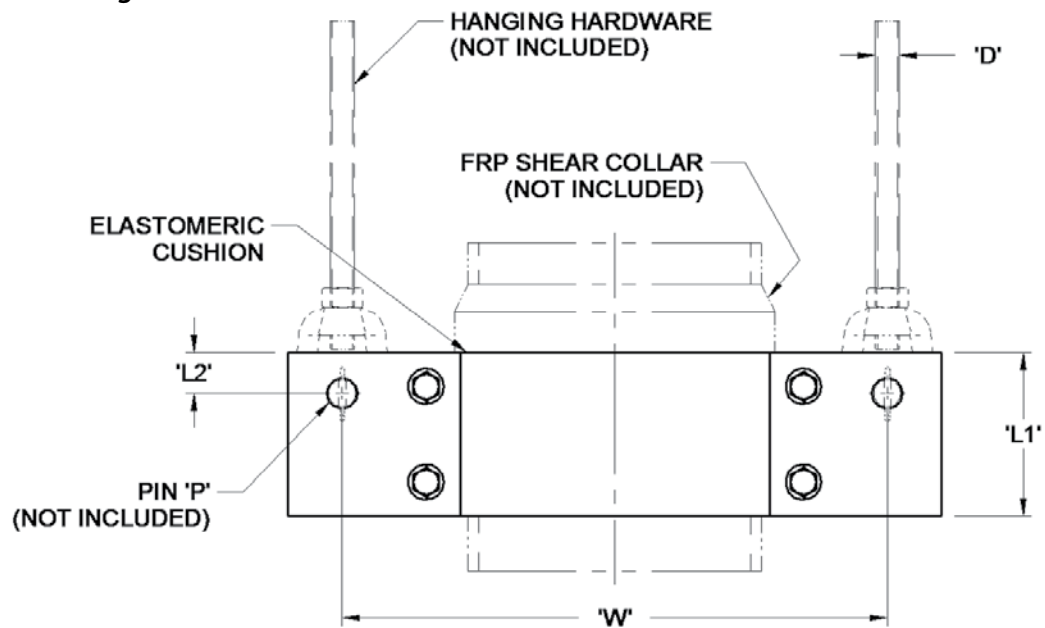

Finish:

Hot-dipped galvanized

See General Note 15, page 5.

Service:

To support weight of pipe from above while allowing freedom of movement

Material:

Carbon steel

See General Note 14, page 5.

Notes:

Support width (W) is based on listed allowable loads. For a greater width, the support configuration may need to be adjusted to suit listed allowable loads. Dimensions are based on typical 150 PSI rated pipe and may vary depending on the actual O.D. and load requirements. Hanging hardware is available upon request. See page 55 for sizes 12" – 30". See General Notes, pages 5 and 6.

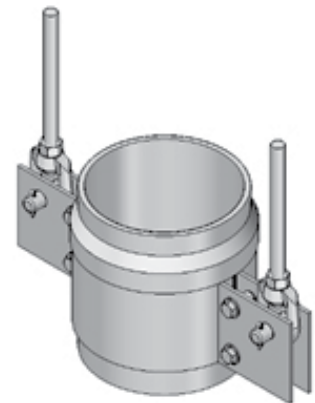

Pipe Size [in]	D [in]	L1 [in]	L2 [in]	P [in]	W [in]	Allowable Loads [lb]
						Vertical
1	3/8	3	1 1/2	1/2	9 1/2	400
1 1/2	3/8	3	1 1/2	1/2	10	550
2	3/8	3	1 1/2	1/2	10 1/2	700
3	1/2	3	1 1/2	5/8	11 1/2	850
4	5/8	3	1 1/2	3/4	12 1/2	1200
6	3/4	4	1 1/8	7/8	15	1600
8	3/4	4	1 1/8	7/8	17	2000
10	7/8	6	1 1/2	1	20	2800

Pipe Supports

Figure P15: Double Rod Riser Hanger
(12"-30" Diameter)

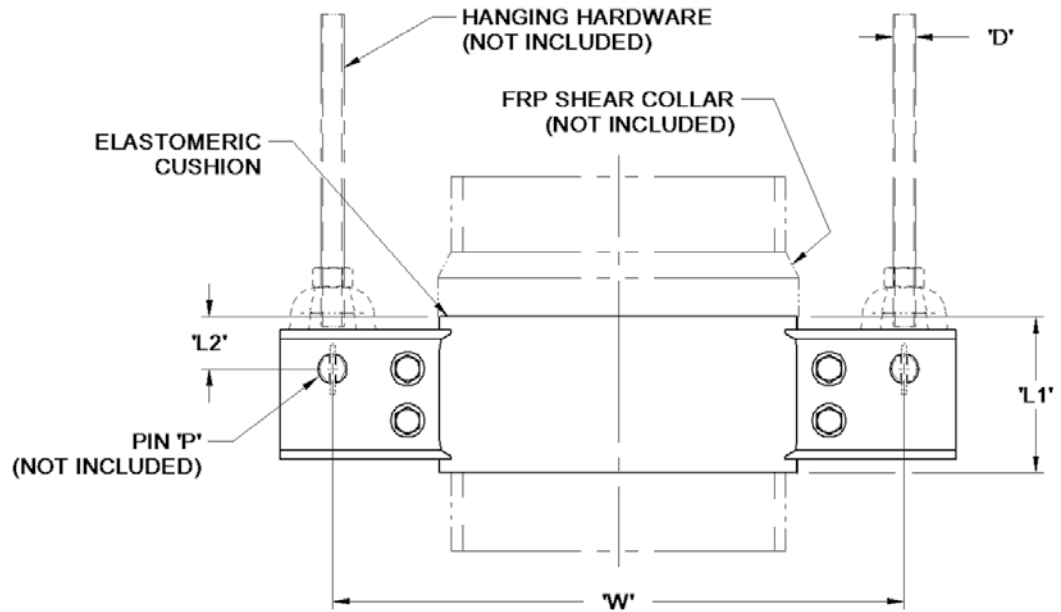

Finish:

Hot-dipped galvanized

See General Note 15, page 5.

Service:

To support weight of pipe from above while allowing freedom of movement

Material:

Carbon steel

See General Note 14, page 5.

Notes:

Support width (W) is based on listed allowable loads. For a greater width, the support configuration may need to be adjusted to suit listed allowable loads. Dimensions are based on typical 150 PSI rated pipe and may vary depending on the actual O.D. and load requirements. Hanging hardware is available upon request. See page 54 for sizes 1" – 10". See General Notes, pages 5 and 6.

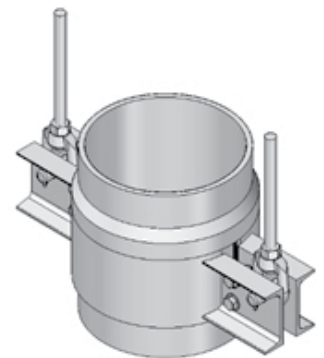

Pipe Size [in]	D [in]	L1 [in]	L2 [in]	P [in]	W [in]	Allowable Loads [lb]
						Vertical
12	7/8	6	2	1	22	3200
14	1	8	2 1/4	1 1/8	24 1/2	4000
16	1	9	2 1/4	1 1/8	26 3/4	4800
18	1	10	2 1/4	1 1/8	28 3/4	5900
20	1 1/4	12	3	1 3/8	32 1/2	7700
24	1 1/4	12	3	1 3/8	36 1/2	9500
30	1 1/2	12	3	1 5/8	43	13500

Pipe Supports

Figure P16: Riser Support W/ Guides
(1"-10" Diameter)

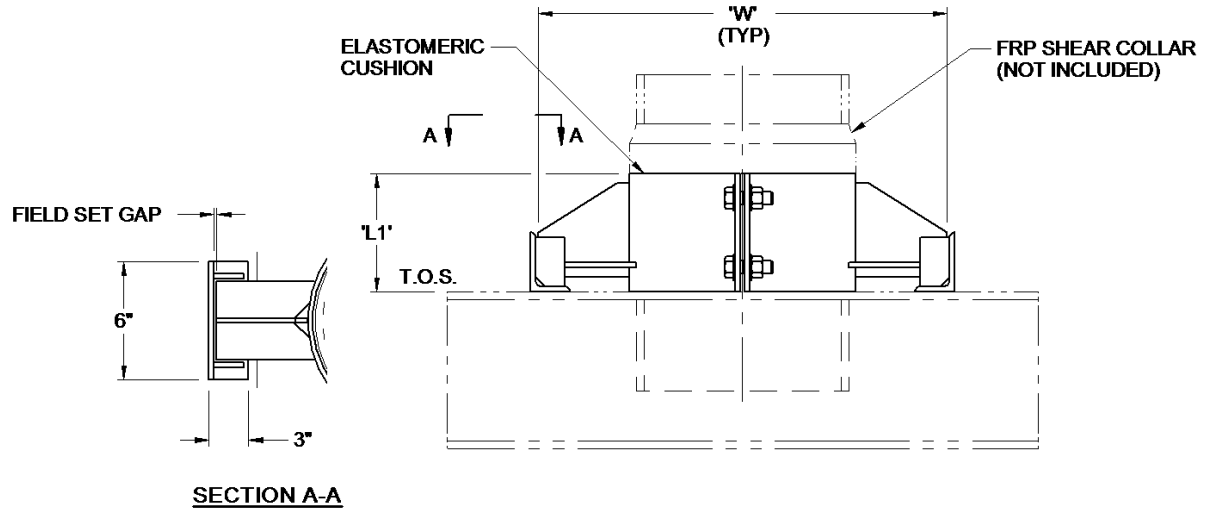

Finish:

Hot-dipped galvanized
See General Note 15, page 5.

Service:

To support weight of pipe while limiting lateral movement

Material:

Carbon steel
See General Note 14, page 5.

Notes:

Support width (W) is based on listed allowable loads. For a greater width, the support configuration may need to be adjusted to suit listed allowable loads. Type RGC1 welded guide clips are provided with this style support. Type RGC2 bolted guide clips are available upon request, page 87. Dimensions are based on typical 150 PSI rated pipe and may vary depending on the actual O.D. and load requirements. See page 57 for sizes 12" – 30". See page 58 for sizes 36" – 60". See General Notes, pages 5 and 6.

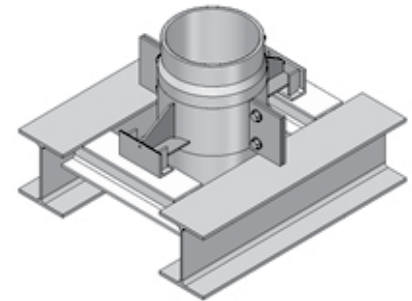

Pipe Size [in]	L1 [in]	W [in]	Allowable Loads [lb]	
			Lateral	Vertical
1	3	10 1/4	80	400
1 1/2	3	10 3/4	100	550
2	3	11 1/4	130	700
3	3	12 1/4	190	850
4	3	13 1/4	240	1200
6	4	15 3/4	360	1600
8	4	17 3/4	480	2000
10	6	20 3/4	650	2800

Pipe Supports

Figure P16: Riser Support W/ Guides
(12"-30" Diameter)

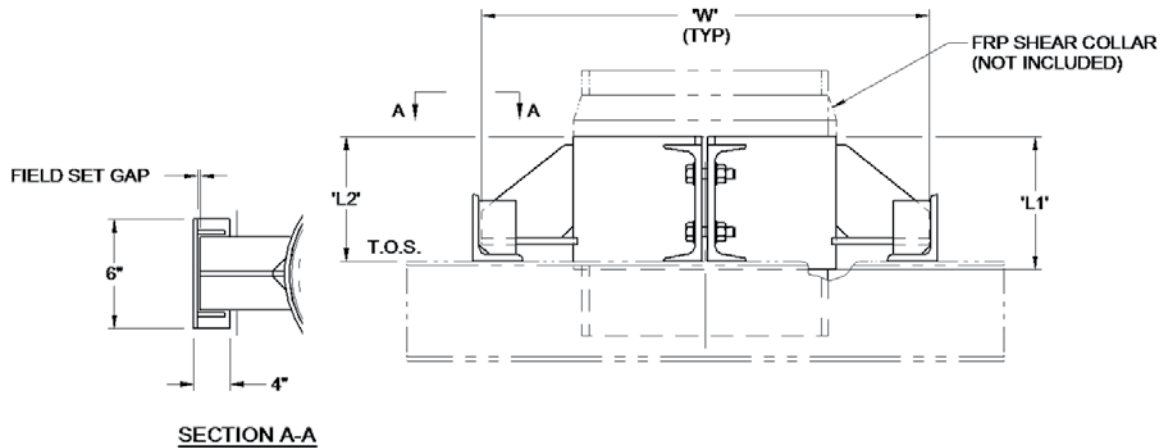

Finish:

Hot-dipped galvanized

See General Note 15, page 5.

Service:

To support weight of pipe while limiting lateral movement

Material:

Carbon steel

See General Note 14, page 5.

Notes:

Support width (W) is based on listed allowable loads. For a greater width, the support configuration may need to be adjusted to suit listed allowable loads. Type RGC1 welded guide clips are provided with this style support. Type RGC2 bolted guide clips are available upon request, page 87. Dimensions are based on typical 150 PSI rated pipe and may vary depending on the actual O.D. and load requirements. See page 56 for sizes 1" – 10". See page 58 for sizes 36" – 60". See General Notes, pages 5 and 6.

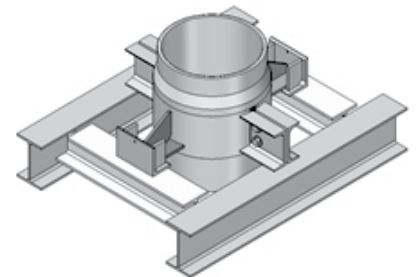

Pipe Size [in]	L1 [in]	L2 [in]	W [in]	Allowable Loads [lb]	
				Lateral	Vertical
12	6	5 1/2	24 3/4	900	3200
14	8	7 1/2	27	1500	4000
16	9	8 1/2	29 1/2	1700	4800
18	10	9 1/2	31 1/2	2300	5900
20	12	11	34	2700	7700
24	12	11	38	3300	9500
30	12	11	44 1/2	4000	13500

Pipe Supports

Figure P16: Riser Support W/ Guides
(36"-60" Diameter)

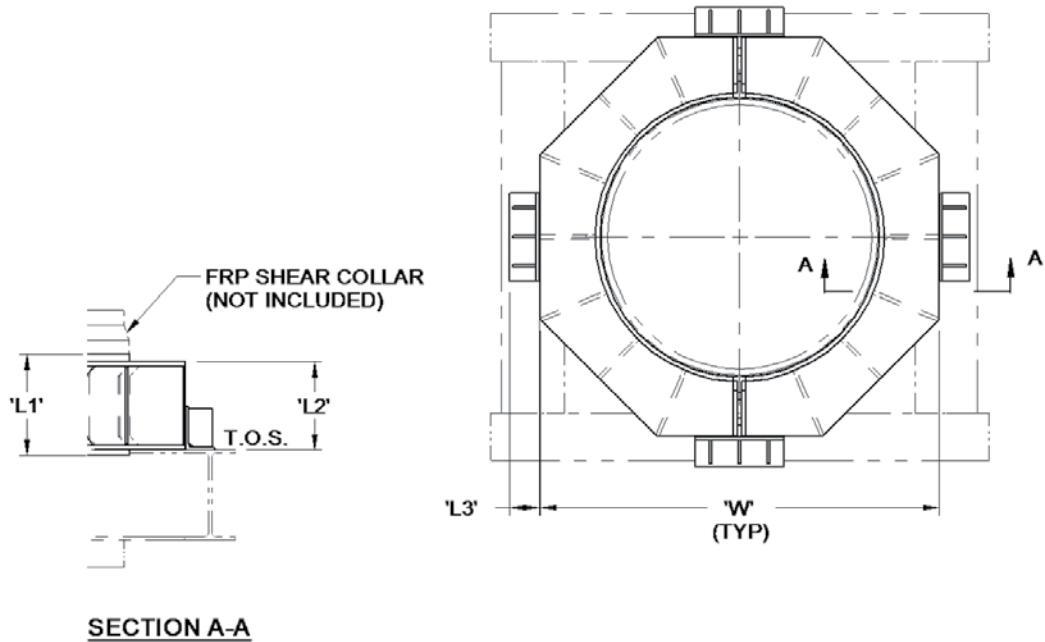

Finish:
Painted
See General Note 15, page 5.

Service:
To support weight of pipe while limiting lateral movement

Material:
Carbon steel

See General Note 14, page 5.

Notes:
Support width (W) is based on listed allowable loads. For a greater width, the support configuration may need to be adjusted to suit listed allowable loads. Type RGC1 welded guide clips are provided with this style support. Type RGC2 bolted guide clips are available upon request, page 87. Dimensions are based on typical 150 PSI rated pipe and may vary depending on the actual O.D. and load requirements. See page 56 for sizes 1" – 10". See page 57 for sizes 12" – 30". See General Notes, pages 5 and 6.

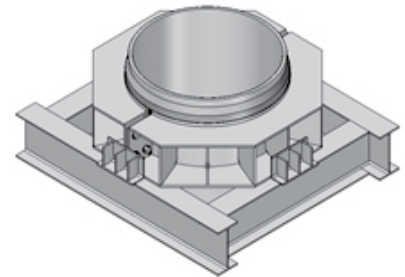

Pipe Size [in]	L1 [in]	L2 [in]	L3 [in]	W [in]	Allowable Loads [lb]	
					Lateral	Vertical
36	12	11	6	53	13000	32000
42	14	13	6	60	17000	45000
48	16	15	6	66 1/2	23000	58000
54	18	18	8	77 3/4	29000	72000
60	20	19	8	80	35000	85000

Pipe Supports

Figure P17: Base Linestop
(12"-30" Diameter)

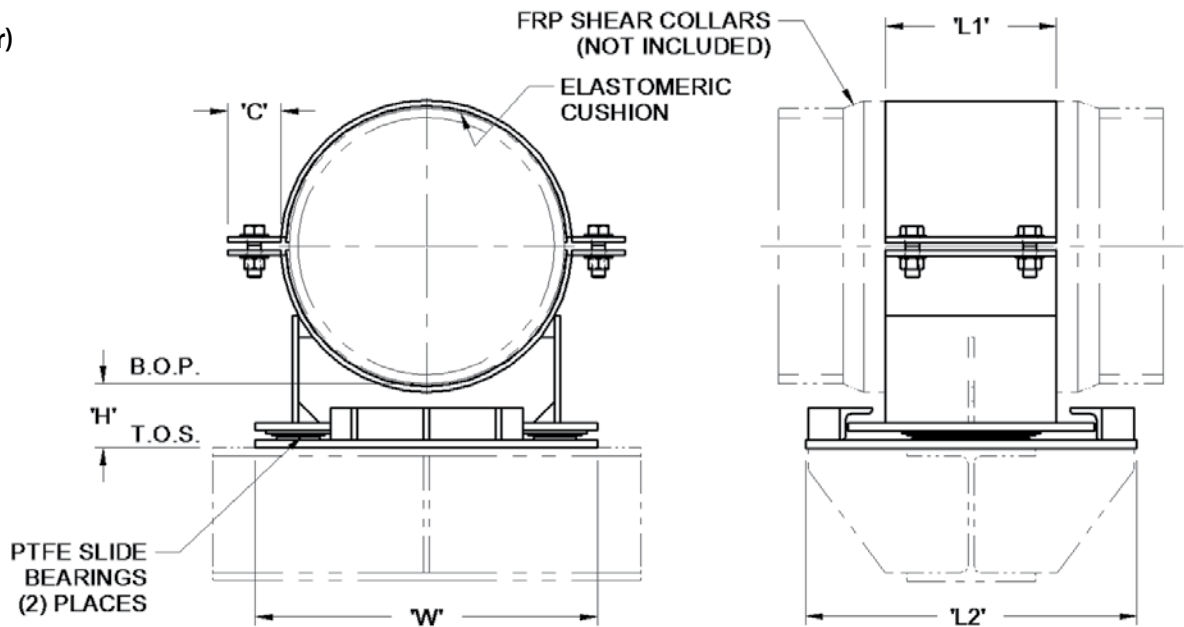

Finish:

Hot-dipped galvanized

See General Note 15, page 5.

Service:

To support weight of pipe while allowing freedom of lateral movement and limiting axial movement

Material:

Carbon steel

See General Note 14, page 5.

Notes:

Base width (W) and length (L2) must be fully supported as shown. If axial and lateral displacements are to be limited, request optional base plate type BP4, page 86. Support is provided with a base plate for welded installations. Base plates for bolted installations are available upon request. Provide bolting arrangement with placement of order. Dimensions are based on typical 150 PSI rated pipe and may vary depending on the actual O.D. and load requirements. PTFE slide bearings are recommended for pipe sizes above 10" NPS. See page 60 for sizes 36" – 60". See General Notes, pages 5 and 6.

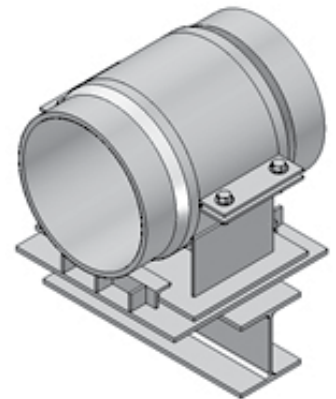

Pipe Size [in]	C [in]	H [in]	L1 [in]	L2 [in]	W [in]	Allowable Loads [lb]	
						Vertical	Axial
12	2 1/2	3	8	15 1/2	16	3900	3500
14	2 1/2	3	10	17 1/2	18	5700	4000
16	2 1/2	3	12	19 1/2	20	7500	6000
18	3	3	14	21 1/2	21 3/4	10000	7000
20	3	3 1/4	14	21 1/2	24	11000	11000
24	3	3 1/4	18	25 1/2	27 3/8	16000	15000
30	3	4	20	30	32 3/4	18000	16000

Pipe Supports

Figure P17: Base Linestop
(36"-60" Diameter)

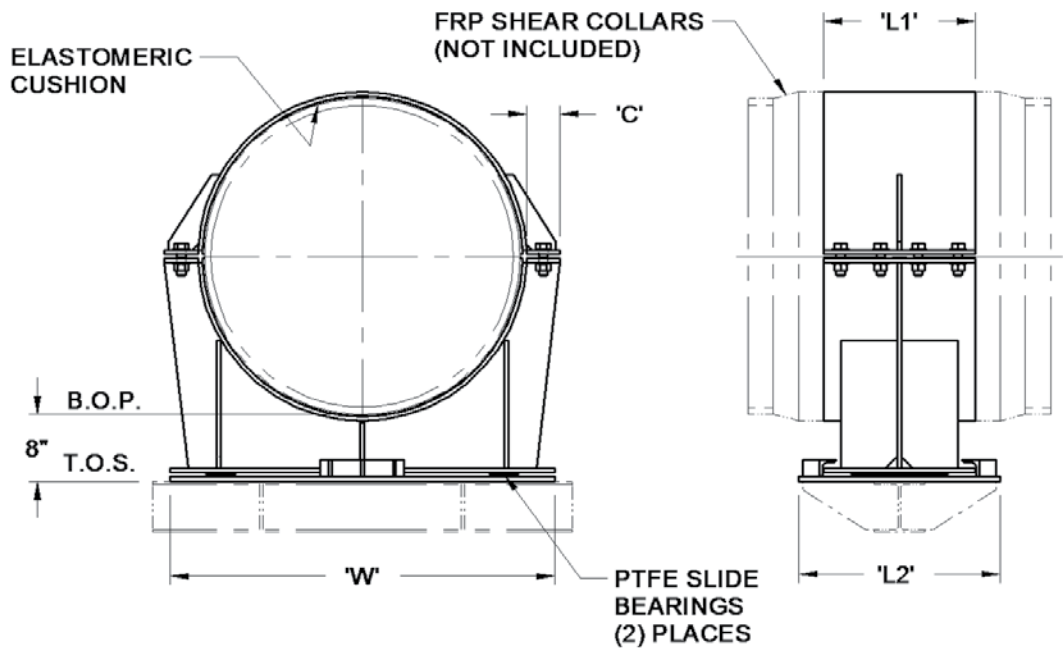

Finish:
Painted
See General Note 15, page 5.

Service:
To support weight of pipe while allowing freedom of lateral movement and limiting axial movement

Material:
Carbon steel
See General Note 14, page 5.

Notes:
Base width (W) and length (L2) must be fully supported as shown. If lateral displacements are to be limited, request optional base plate type BP4, page 86 and provide load requirements. Support is provided with a base plate for welded installations. Base plates for bolted installations are available upon request. Provide bolting arrangement with placement of order. Dimensions are based on typical 150 PSI rated pipe and may vary depending on the actual O.D. and load requirements. PTFE slide bearings are recommended for pipe sizes above 10" NPS. See page 59 for sizes 12" – 30". See General Notes, pages 5 and 6.

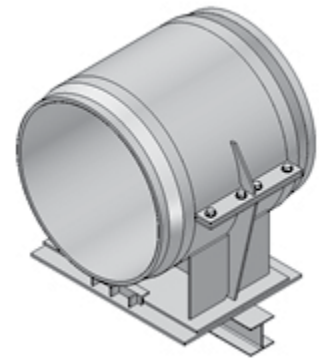

Pipe Size [in]	C [in]	L1 [in]	L2 [in]	W [in]	Allowable Loads [lb]	
					Vertical	Axial
36	4	24	30 1/2	40	21000	18000
42	4	26	32 1/2	47	30000	24000
48	4	28	34 1/2	53 1/4	39000	30000
54	4	30	37 1/4	57 3/4	48000	36000
60	4	32	39 1/4	63 1/4	56000	40000

Pipe Supports

Figure P18: Base Slide
(12"-30" Diameter)

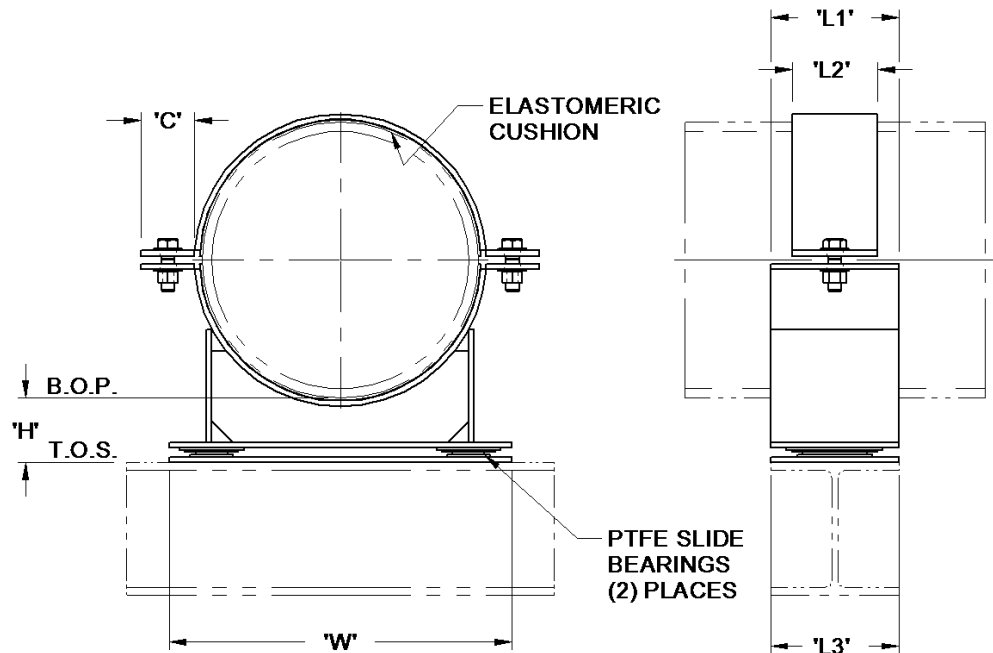

Finish:

Hot-dipped galvanized

See General Note 15, page 5.

Service:

To support weight of pipe while allowing freedom of movement

Material:

Carbon steel

See General Note 14, page 5.

Notes:

Support is provided with a base plate for welded installations. Base plates for bolted installations are available upon request. Provide bolting arrangement with placement of order. Dimensions are based on typical 150 PSI rated pipe and may vary depending on the actual O.D. and load requirements. PTFE slide bearings are recommended for pipe sizes above 10" NPS. See page 62 for sizes 36" – 60". See General Notes, pages 5 and 6.

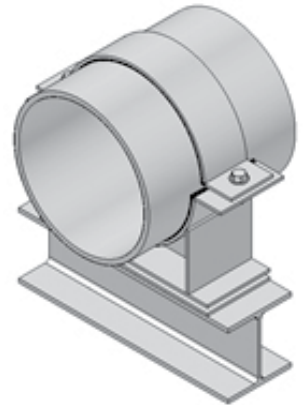

Pipe Size [in]	C [in]	H [in]	L1 [in]	L2 [in]	L3 [in]	W [in]	Allowable Loads [lb]
							Vertical
12	2 1/2	3	6	4	6	16	3200
14	2 1/2	3	8	6	8	18	4950
16	2 1/2	3	8	6	8	20	5700
18	3	3	10	6	8	21 3/4	8000
20	3	3 1/4	10	6	8	24	8900
24	3	3 1/4	12	8	10	27 3/8	12600
30	3	4	15	10	12	32 3/4	15000

Pipe Supports

Figure P18: Base Slide
(36"-60" Diameter)

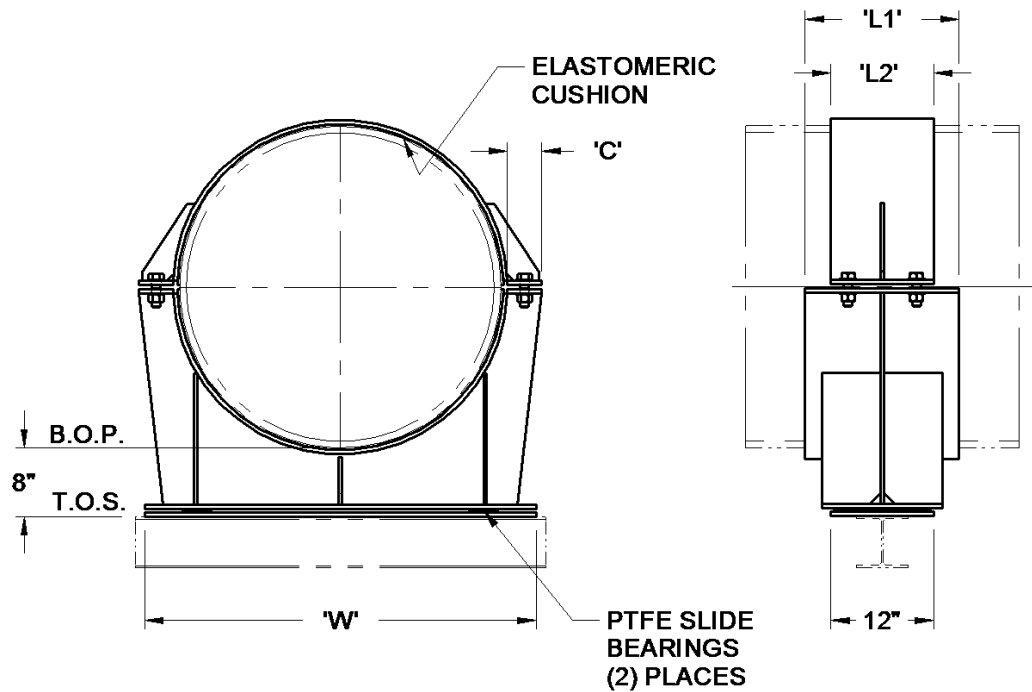

Finish:
Painted
See General Note 15, page 5.

Service:
To support weight of pipe while allowing freedom of movement

Material:
Carbon steel
See General Note 14, page 5.

Notes:
Support is provided with a base plate for welded installations. Base plates for bolted installations are available upon request. Provide bolting arrangement with placement of order. Dimensions are based on typical 150 PSI rated pipe and may vary depending on the actual O.D. and load requirements. PTFE slide bearings are recommended for pipe sizes above 10" NPS. See page 61 for sizes 12" – 30". See General Notes, pages 5 and 6.

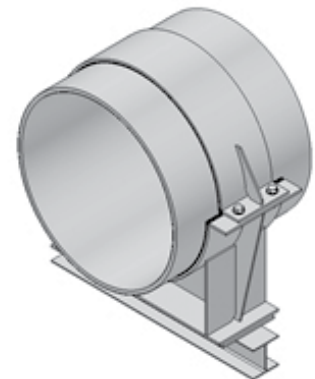

Pipe Size [in]	C [in]	L1 [in]	L2 [in]	W [in]	Allowable Loads [lb]
					Vertical
36	4	18	12	40	21000
42	4	21	14	47	30000
48	4	24	16	53 1/4	39000
54	4	27	18	57 3/4	48000
60	4	30	20	63 1/4	56000

Pipe Supports

Figure P19: Base Guide
(12"-30" Diameter)

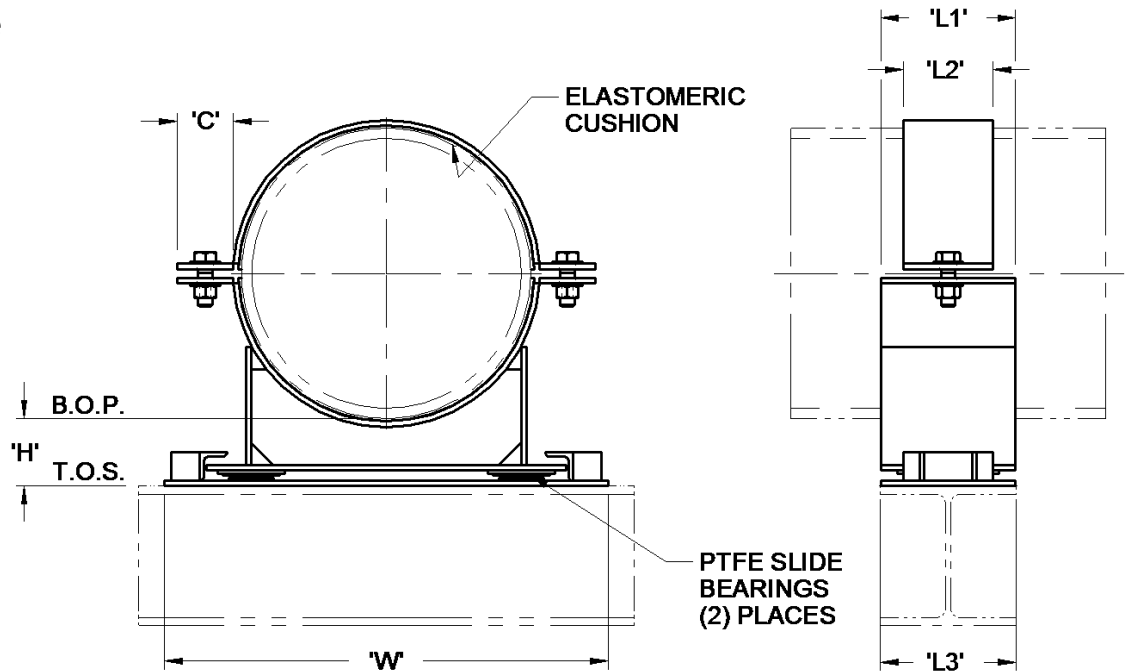

Finish:

Hot-dipped galvanized

See General Note 15, page 5.

Service:

To support weight of pipe while limiting lateral movement

Material:

Carbon steel

See General Note 14, page 5.

Notes:

Support is provided with a base plate for welded installations. Base plates for bolted installations are available upon request. Provide bolting arrangement with placement of order. Dimensions are based on typical 150 PSI rated pipe and may vary depending on the actual O.D. and load requirements. PTFE slide bearings are recommended for pipe sizes above 10" NPS. See page 64 for sizes 36" – 60". See General Notes, pages 5 and 6.

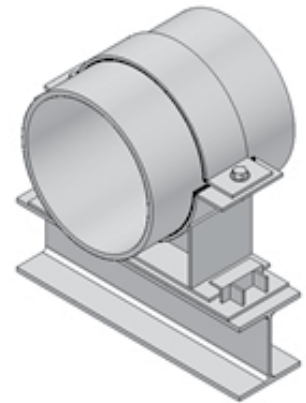

Pipe Size [in]	C [in]	H [in]	L1 [in]	L2 [in]	L3 [in]	W [in]	Allowable Loads [lb]	
							Lateral	Vertical
12	2 1/2	3	6	4	6	19 3/4	900	3000
14	2 1/2	3	8	6	8	21 3/4	1500	4600
16	2 1/2	3	8	6	8	23 3/4	1700	5400
18	3	3	10	6	8	25 1/2	2300	7500
20	3	3 1/4	10	6	8	27 3/4	2700	8200
24	3	3 1/4	12	8	10	31 1/8	5200	11000
30	3	4	15	10	12	38	7500	15000

Pipe Supports

Figure P19: Base Guide
(36"-60" Diameter)

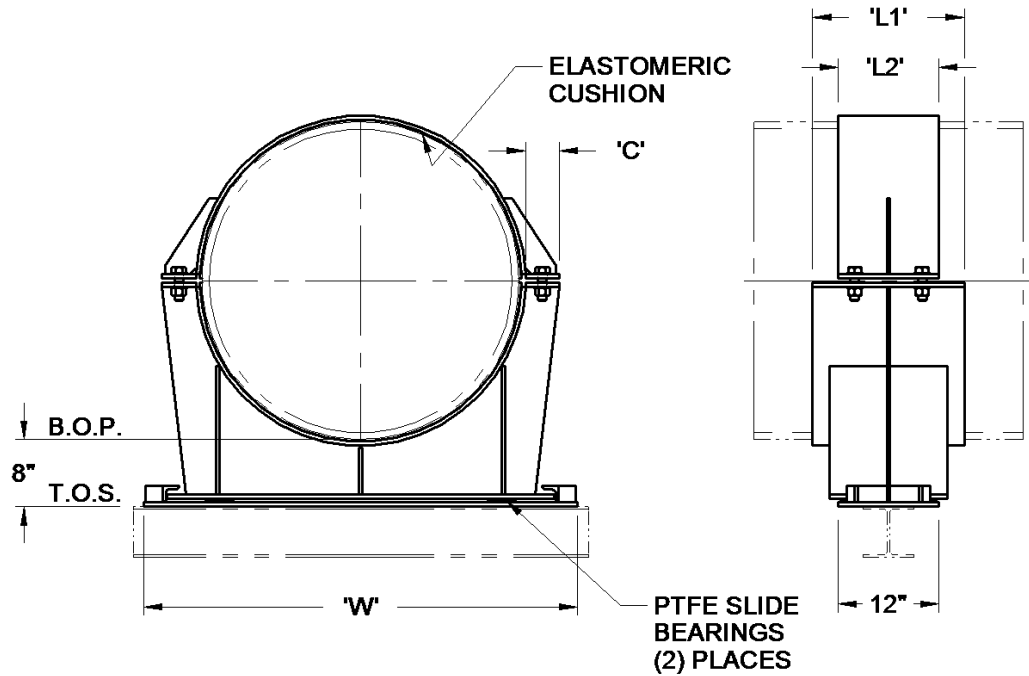

Finish:
Painted
See General Note 15, page 5.

Service:
To support weight of pipe while limiting lateral movement

Material:
Carbon steel
See General Note 14, page 5.

Notes:
Support is provided with a base plate for welded installations. Base plates for bolted installations are available upon request. Provide bolting arrangement with placement of order. Dimensions are based on typical 150 PSI rated pipe and may vary depending on the actual O.D. and load requirements. PTFE slide bearings are recommended for pipe sizes above 10" NPS. See page 63 for sizes 12" – 30". See General Notes, pages 5 and 6.

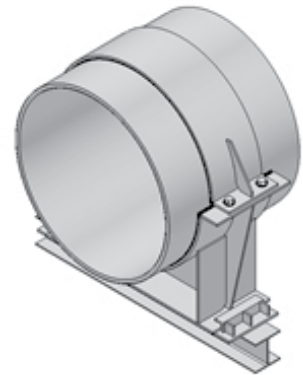

Pipe Size [in]	C [in]	L1 [in]	L2 [in]	W [in]	Allowable Loads [lb]	
					Lateral	Vertical
36	4	18	12	47	14000	21000
42	4	21	14	53 1/2	19000	30000
48	4	24	16	60	25000	39000
54	4	27	18	66	31000	48000
60	4	30	20	71 1/2	37000	56000

Pipe Supports

Figure P20: Base Anchor
(12"-30" Diameter)

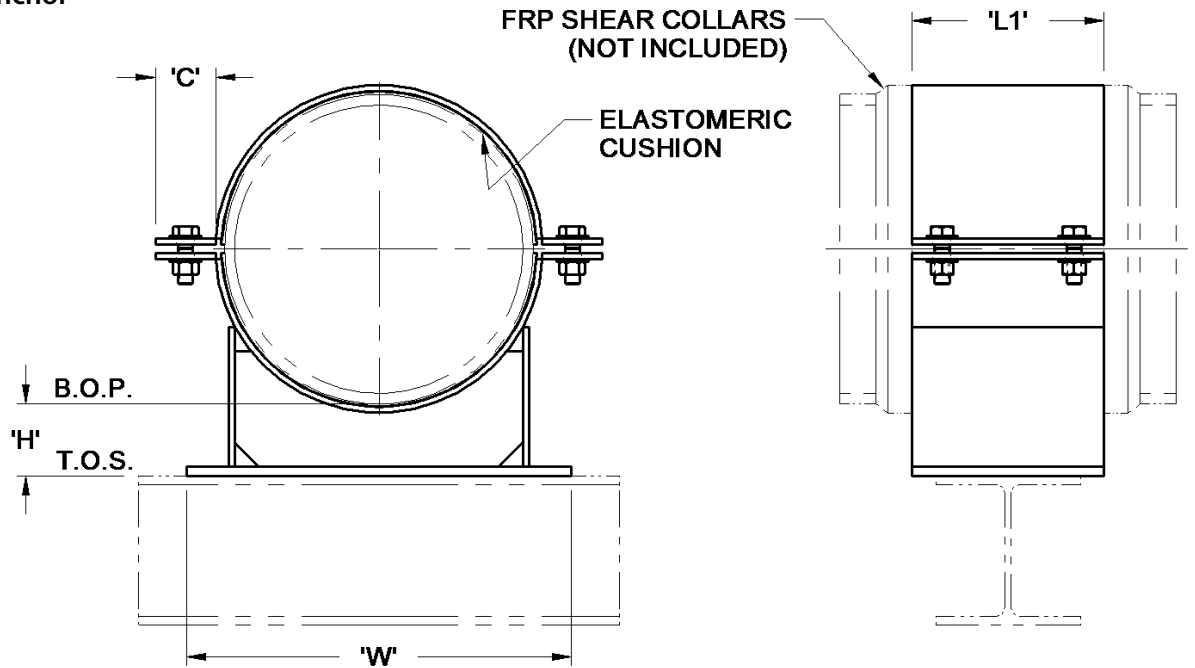

Finish:

Hot-dipped galvanized

See General Note 15, page 5.

Service:

To support weight of pipe while restricting all movement

Material:

Carbon steel

See General Note 14, page 5.

Notes:

Base width (W) must be fully supported as shown. Support is provided with a base plate for welded installations. Base plates for bolted installations are available upon request. Provide bolting arrangement with placement of order. Dimensions are based on typical 150 PSI rated pipe and may vary depending on the actual O.D. and load requirements. See page 66 for sizes 36" – 60". See General Notes, pages 5 and 6.

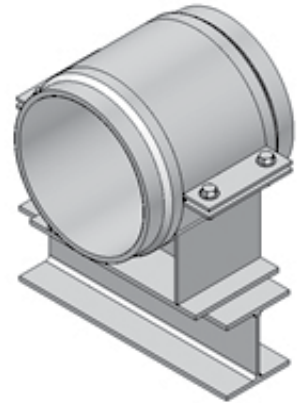

Pipe Size [in]	C [in]	H [in]	L1 [in]	W [in]	Allowable Loads [lb]		
					Lateral	Vertical	Axial
12	2 1/2	3	8	16	1600	3900	3500
14	2 1/2	3	10	18	2300	5700	4000
16	2 1/2	3	12	20	3500	7500	6000
18	3	3	14	21 3/4	4500	10000	7000
20	3	3 1/4	14	24	5500	11000	11000
24	3	3 1/4	18	27 3/8	8000	16000	15000
30	3	4	20	32 3/4	9000	18000	16000

Pipe Supports

Figure P20: Base Anchor
(36"-60" Diameter)

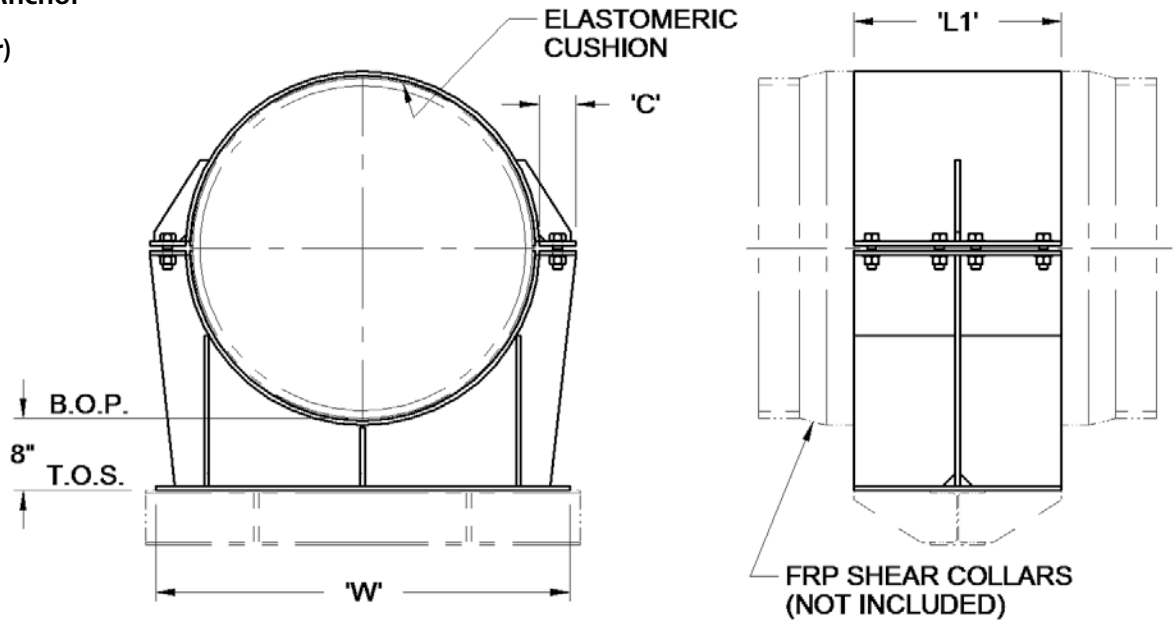

Finish:

Painted

See General Note 15, page 5.

Service:

To support weight of pipe while restricting all movement

Material:

Carbon steel

See General Note 14, page 5.

Notes:

Base width (W) must be fully supported as shown. Support is provided with a base plate for welded installations. Base plates for bolted installations are available upon request. Provide bolting arrangement with placement of order. Dimensions are based on typical 150 PSI rated pipe and may vary depending on the actual O.D. and load requirements. See page 65 for sizes 12" – 30". See General Notes, pages 5 and 6.

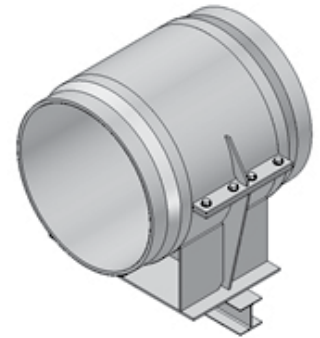

Pipe Size [in]	C [in]	L1 [in]	W [in]	Allowable Loads [lb]		
				Lateral	Vertical	Axial
36	4	24	40	10000	21000	21000
42	4	26	47	15000	30000	30000
48	4	28	53 1/4	19000	39000	39000
54	4	30	57 3/4	24000	48000	45000
60	4	32	63 1/4	32000	56000	50000

Pipe Supports

Figure XL12: Extra Large Slide
(66"-108" Diameter)

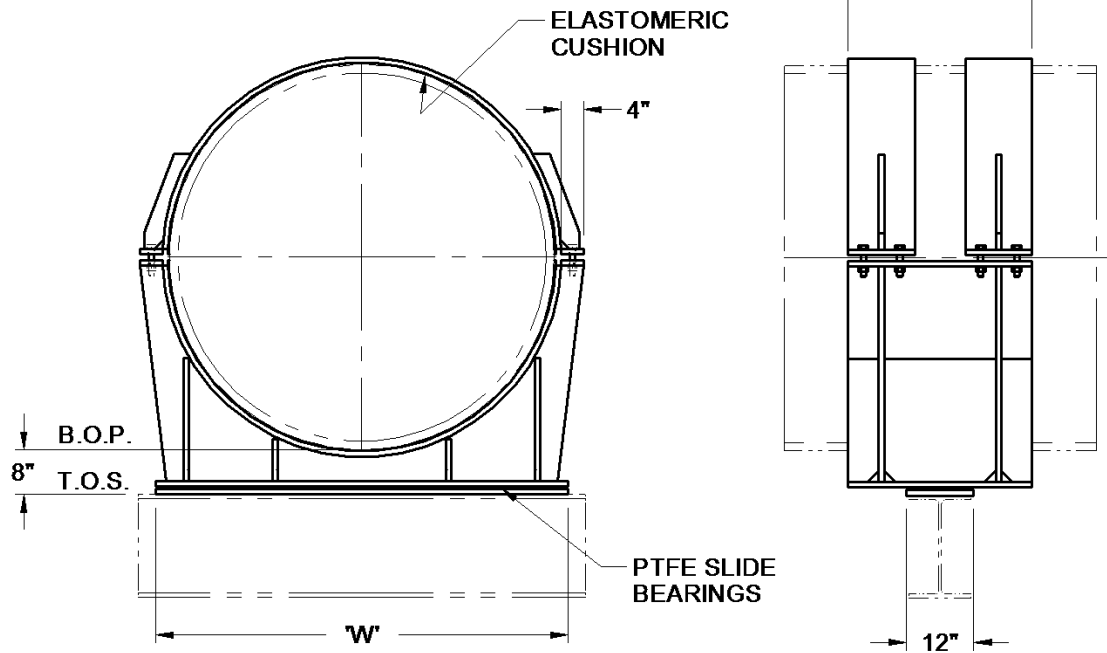

Finish:

Painted

See General Note 15, page 5.

Service:

To support weight of pipe or duct while allowing freedom of movement

Material:

Carbon steel

See General Note 14, page 5.

Notes:

Large diameter pipe supports are engineered to suit project requirements. Contact us for further information and how to order. Base width (W) must be fully supported as shown. Support is provided with a base plate for welded installations. Base plates for bolted installations are available upon request. Provide bolting arrangement with placement of order. PTFE slide bearings are recommended. Where increase friction is desirable, the base plate and bearing(s) may be eliminated. Dimensions may vary depending on actual pipe O.D. and load requirements. See General Notes, pages 5 and 6.

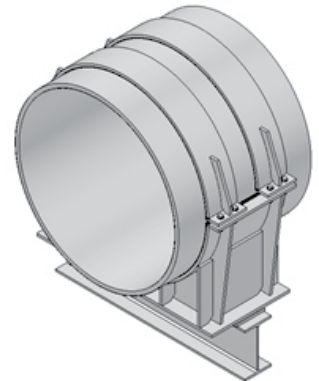

Pipe Size [in]	L1 [in]	W [in]
66	33	74
72	36	80
78	39	90
84	42	92
90	45	98
96	48	104
102	48	110
108	48	116

Pipe Supports

Figure XL13: Extra Large Slide
(66"-108" Diameter)

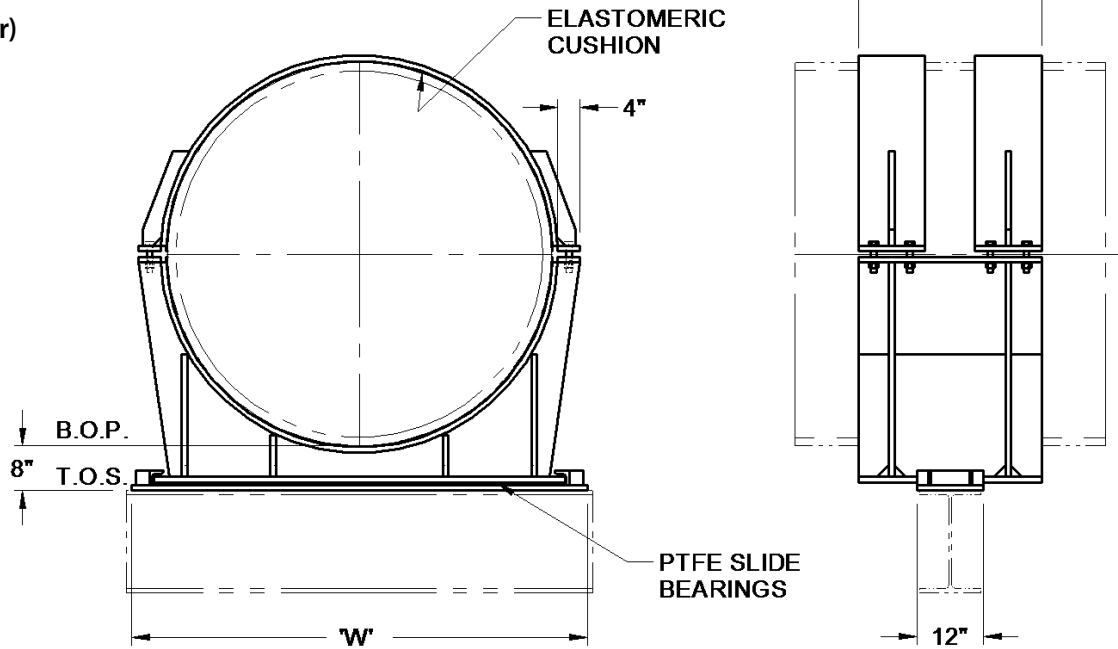

Finish:

Painted

See General Note 15, page 5.

Service:

To support weight of pipe or duct while allowing freedom of axial movement and limiting lateral movement

Material:

Carbon steel

See General Note 14, page 5.

Notes:

Large diameter pipe supports are engineered to suit project requirements. Contact us for further information and how to order. Base width (W) must be fully supported as shown. Support is provided with a base plate for welded installations. Base plates for bolted installations are available upon request. Provide bolting arrangement with placement of order. PTFE slide bearings are recommended. Where increase friction is desirable, the base plate and bearing(s) may be eliminated. Dimensions may vary depending on actual pipe O.D. and load requirements. See General Notes, pages 5 and 6.

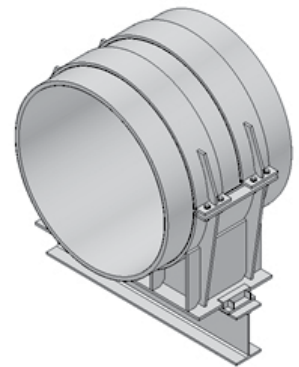

Pipe Size [in]	L1 [in]	W [in]
66	33	80
72	36	86
78	39	96
84	42	98
90	45	104
96	48	110
102	48	116
108	48	122

Pipe Supports

Figure XL14: Extra Large Anchor
(66"-108" Diameter)

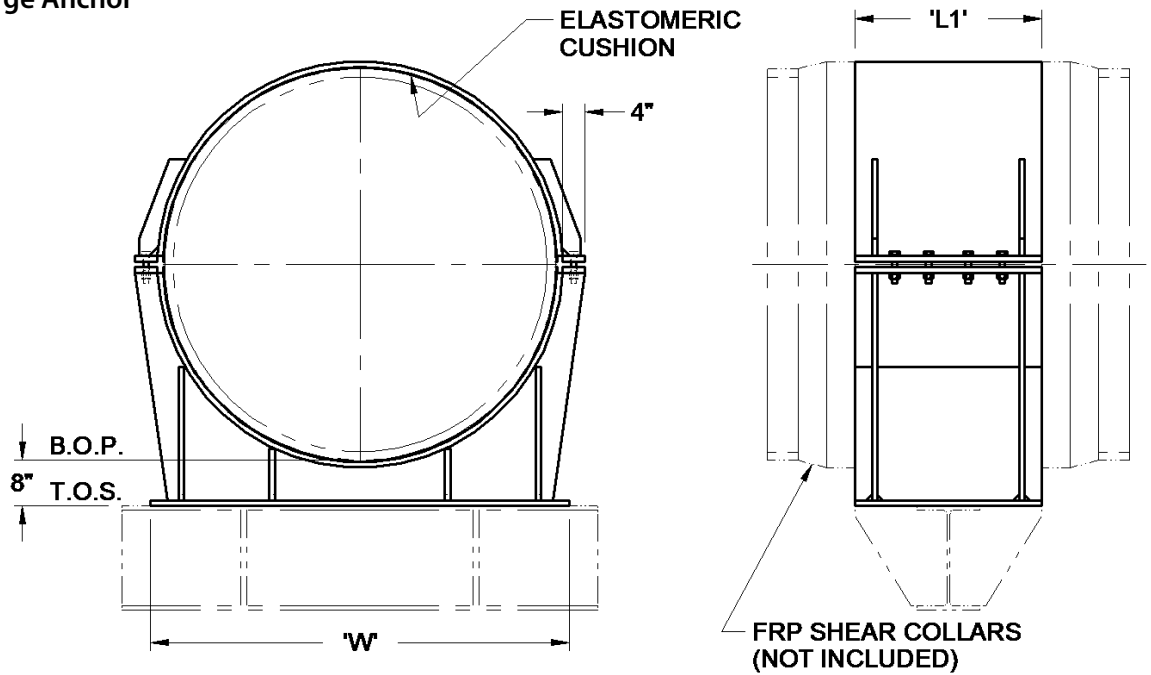

Finish:

Painted

See General Note 15, page 5.

Service:

To support weight of pipe or duct while restricting all movement

Material:

Carbon steel

See General Note 14, page 5.

Notes:

Large diameter pipe supports are engineered to suit project requirements. Contact us for further information and how to order. Base width (W) must be fully supported as shown. Support is provided with a base plate for welded installations. Base plates for bolted installations are available upon request. Provide bolting arrangement with placement of order. Dimensions may vary depending on actual pipe O.D. and load requirements. See General Notes, pages 5 and 6.

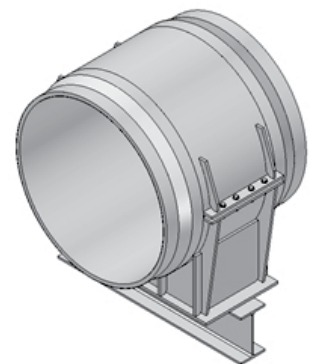

Pipe Size [in]	L1 [in]	W [in]
66	33	74
72	36	80
78	39	90
84	42	92
90	45	98
96	48	104
102	48	110
108	48	116

Duct Supports

Figure D1: Duct Clamp Hanger
(20"-60" Diameter)

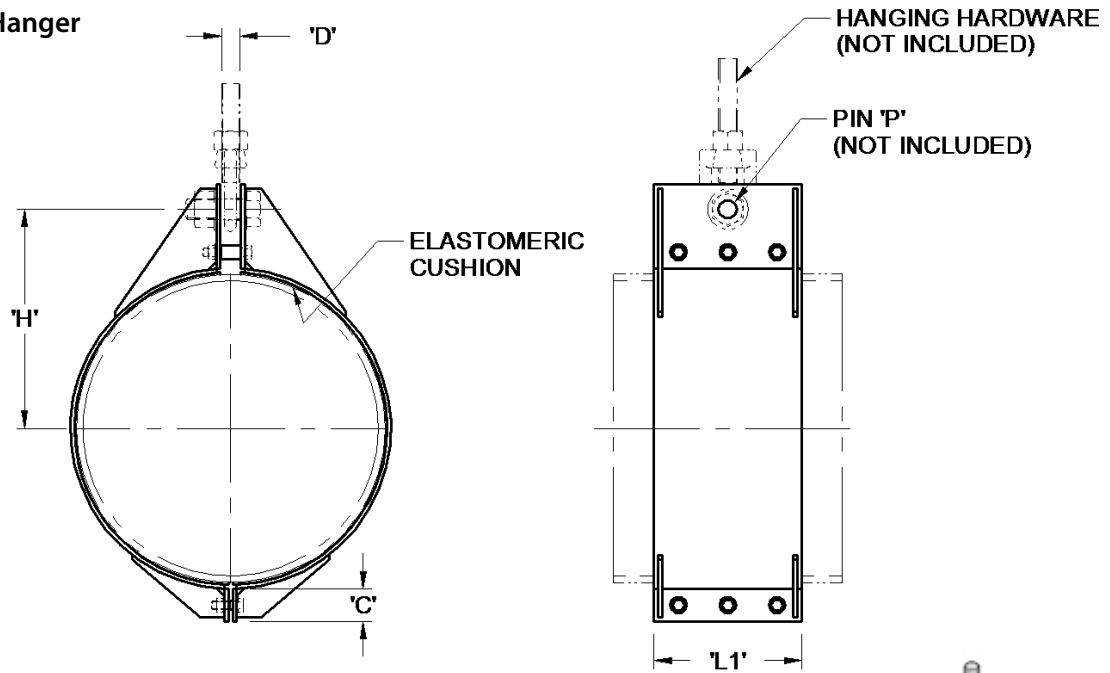

Finish:

20" – 30": Hot-dipped galvanized

36" – 60": Painted

See General Note 15, page 5.

Service:

To support weight of duct from above while allowing freedom of movement

Material:

Carbon steel

See General Note 14, page 5.

Notes:

Dimensions may vary depending on the actual O.D. and load requirements. Hanging hardware is available upon request. See General Notes, pages 5 and 6.

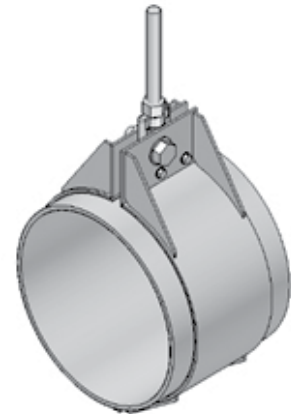

Pipe Size [in]	C [in]	D [in]	H [in]	L1 [in]	P [in]	Allowable Loads [lb]
						Vertical
20	2 1/2	1/2	15 3/4	6	5/8	900
24	2 1/2	1/2	18 3/16	6	5/8	1200
30	2 1/2	5/8	22	8	3/4	1750
36	2 1/2	3/4	26	10	7/8	2400
42	3	7/8	30 3/8	10	1	3750
48	3	1	35 1/4	12	1 1/8	4750
54	3	1 1/4	37 3/16	16	1 3/8	6000
60	3	1 1/4	40 1/4	16	1 3/8	7500

Pipe Supports

Figure D3: Duct Cradle Base Slide

(20"-60" Diameter)

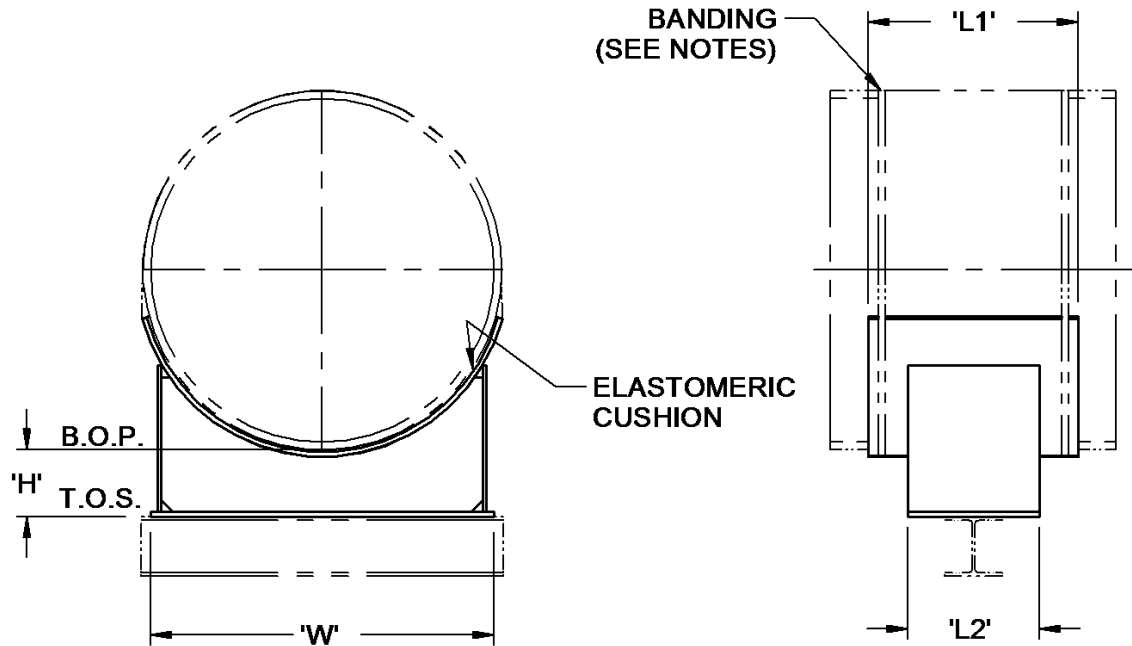

Finish:

20" – 30": Hot-dipped galvanized

36" – 60": Painted

See General Note 15, page 5.

Service:

To support weight of duct while allowing freedom of movement

Material:

Carbon steel

See General Note 14, page 5.

Notes:

Not designed for lateral or axial loads. Base width (W) must be fully supported as shown. Dimensions may vary depending on the actual O.D. and load requirements. Banding can be provided (in bulk) upon request. See General Note 26, page 6.

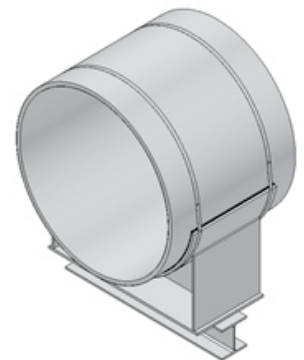

Pipe Size [in]	H [in]	L1 [in]	L2 [in]	W [in]	Allowable Loads [lb]
					Vertical
20	7	10	6	21	450
24	7	10	6	25	600
30	8	10	6	30	875
36	8	10	6	36	1200
42	8	12	8	42	1875
48	8	12	8	48	2375
54	8	16	12	54	3000
60	8	16	12	60	3750

Pipe Supports

Figure D4: Duct Base Linestop
(20"-36" Diameter)

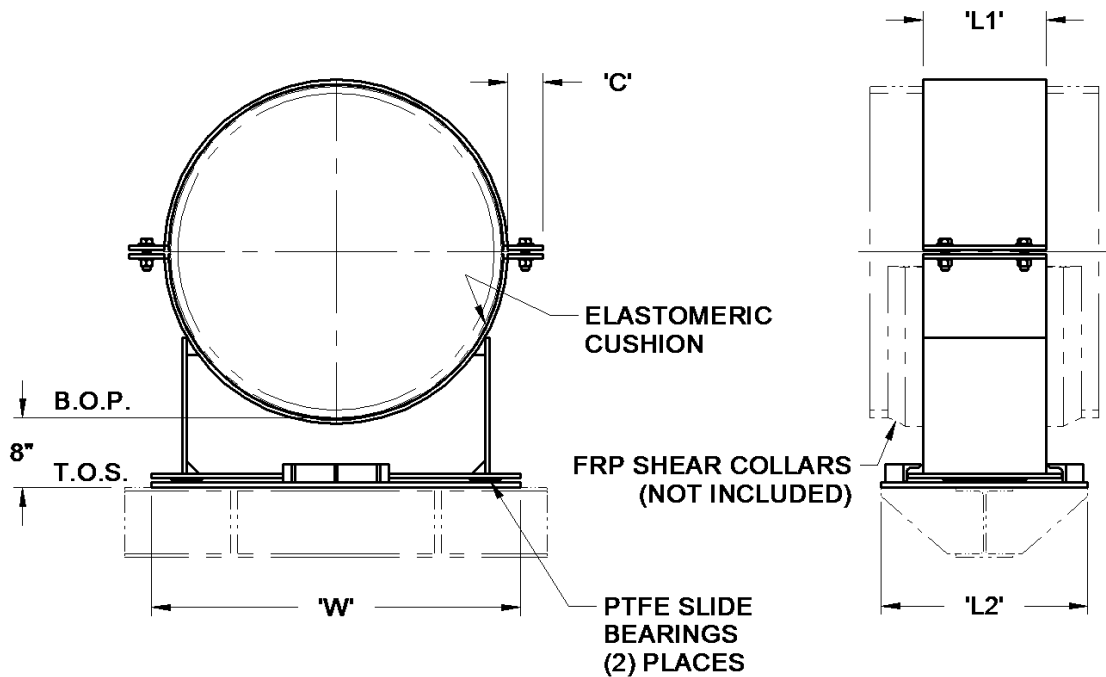

Finish:

20" – 30": Hot-dipped galvanized

36": Painted

See General Note 15, page 5.

Service:

To support weight of duct while allowing freedom of lateral movement and limiting axial movement

Material:

Carbon steel

See General Note 14, page 5.

Notes:

Base width (W) and length (L2) must be fully supported as shown. If lateral displacements are to be limited, request optional base plate type BP4, page 86 and provide loads for evaluation. Support is provided with a base plate for welded installation. Base plates for bolted installations are available upon request. Provide bolting arrangement with placement of order. Dimensions may vary depending on the actual O.D. and load requirements. PTFE slide bearings are recommended. See page 73 for sizes 42" – 60". See General Notes, pages 5 and 6.

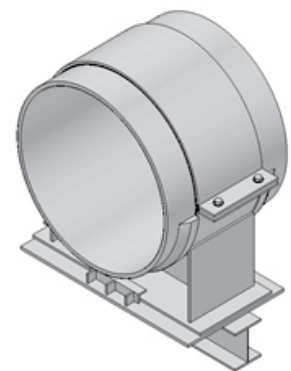

Pipe Size [in]	C [in]	L1 [in]	L2 [in]	W [in]	Allowable Loads [lb]	
					Vertical	Axial
20	2 1/2	8	15 1/2	24	900	1800
24	2 1/2	8	15 1/2	27 3/8	1200	2100
30	2 1/2	10	20	31 3/4	1750	3000
36	2 1/2	12	22	36	2400	4200

Pipe Supports

Figure D4: Duct Base Linestop
(42"-60" Diameter)

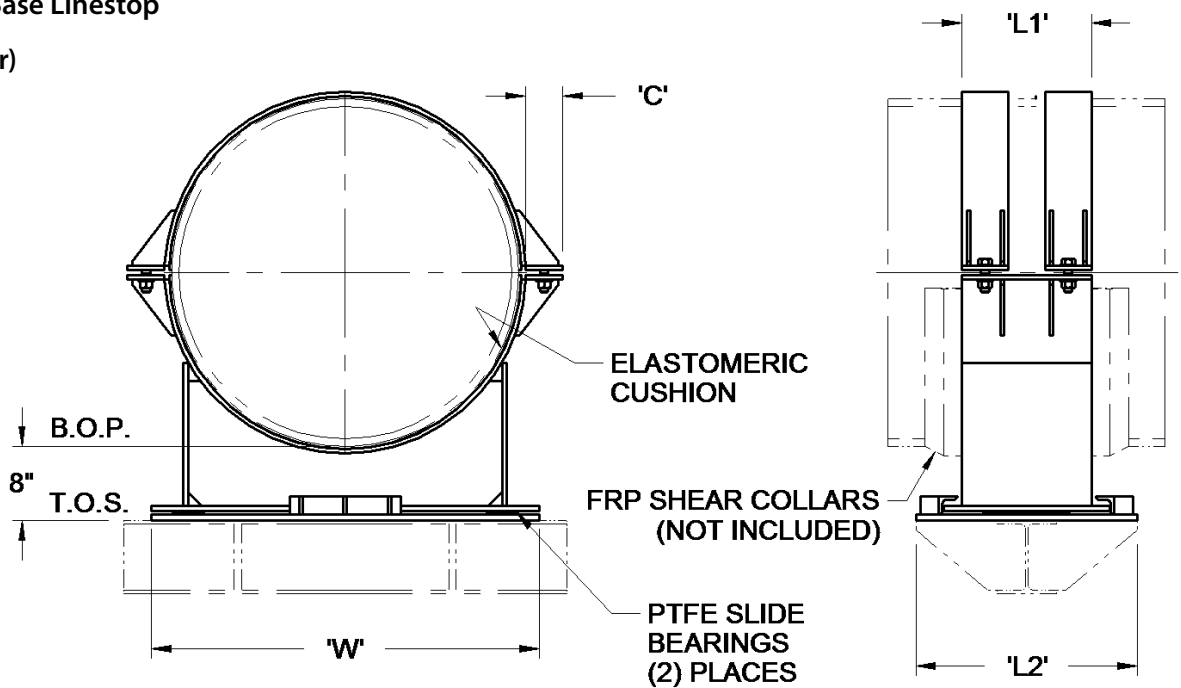

Finish:

Painted

See General Note 15, page 5.

Service:

To support weight of duct while allowing freedom of lateral movement and limiting axial movement

Material:

Carbon steel

See General Note 14, page 5.

Notes:

Base width (W) and length (L2) must be fully supported as shown. If lateral displacements are to be limited, request optional base plate type BP4, page 86 and provide loads for evaluation. Support is provided with a base plate for welded installation. Base plates for bolted installations are available upon request. Provide bolting arrangement with placement of order. Dimensions may vary depending on the actual O.D. and load requirements. PTFE slide bearings are recommended. See page 72 for sizes 20" – 36". See General Notes, pages 5 and 6.

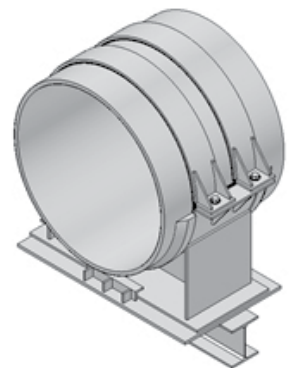

Pipe Size [in]	C [in]	L1 [in]	L2 [in]	W [in]	Allowable Loads [lb]	
					Vertical	Axial
42	3	14	24 1/2	43	3750	6000
48	3	16	26 1/2	49 1/4	4750	7500
54	3	18	29 1/4	53 3/4	6000	9000
60	3	20	31 1/4	59 1/4	7500	12000

Pipe Supports

Figure D5: Duct Base Slide
(20"-36" Diameter)

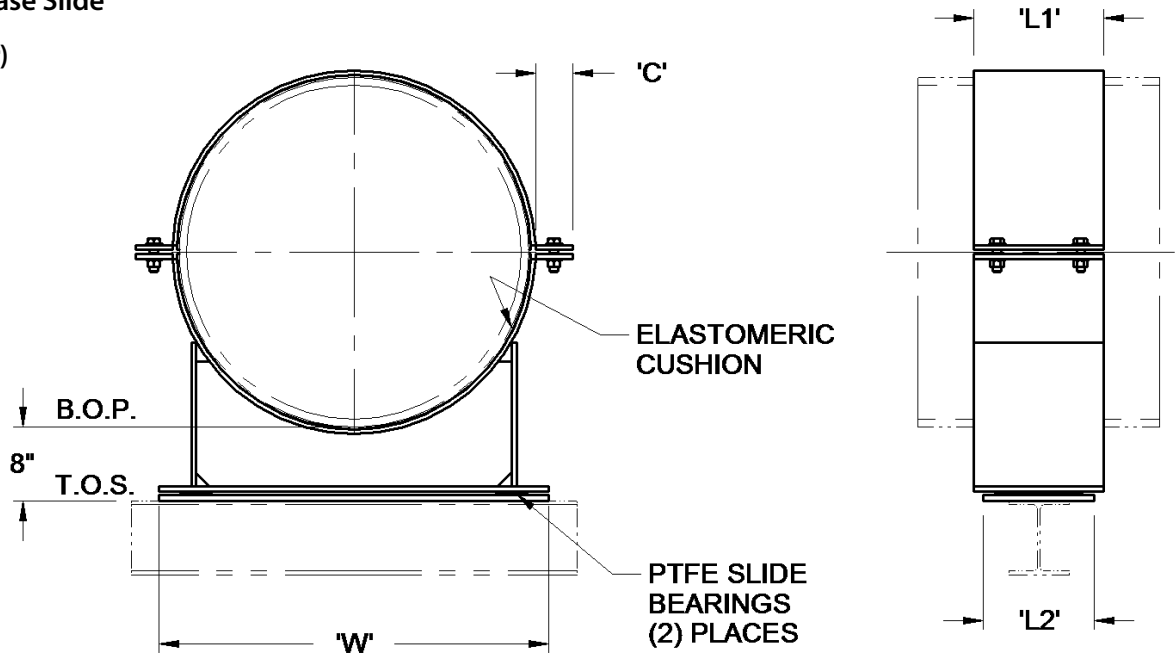

Finish:

20" – 30": Hot-dipped galvanized

36": Painted

See General Note 15, page 5.

Service:

To support weight of duct while allowing freedom of movement

Material:

Carbon steel

See General Note 14, page 5.

Notes:

Support is provided with a base plate for welded installation. Base plates for bolted installations are available upon request. Provide bolting arrangement with placement of order. Dimensions may vary depending on the actual O.D. and load requirements. PTFE slide bearings are recommended. See page 75 for sizes 42" – 60". See General Notes, pages 5 and 6.

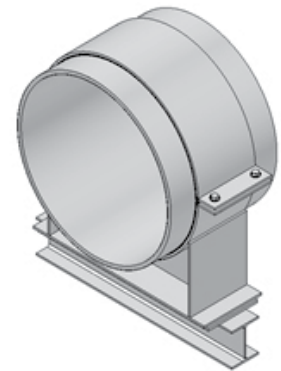

Pipe Size [in]	C [in]	L1 [in]	L2 [in]	W [in]	Allowable Loads [lb]
					Vertical
20	2 1/2	6	6	24	900
24	2 1/2	6	6	27 3/4	1200
30	2 1/2	8	6	31 3/4	1750
36	2 1/2	10	8	36	2400

Pipe Supports

Figure D5: Duct Base Slide
(42"-60" Diameter)

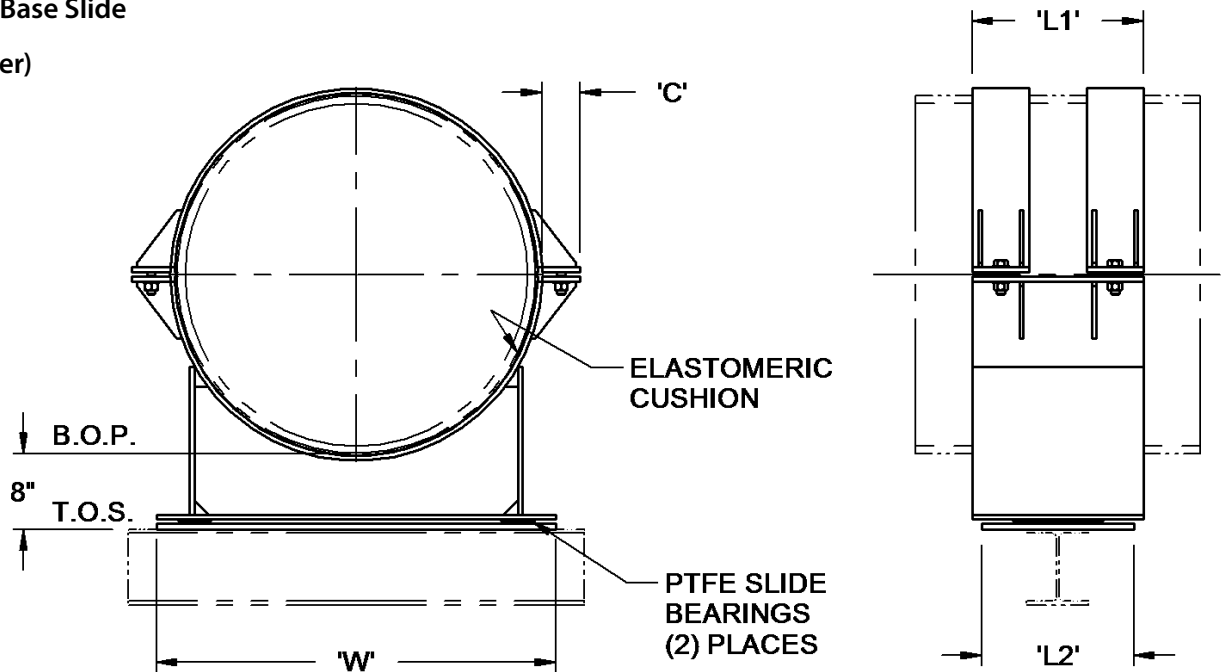

Finish:

Painted

See General Note 15, page 5.

Service:

To support weight of duct while allowing freedom of movement

Material:

Carbon steel

See General Note 14, page 5.

Notes:

Support is provided with a base plate for welded installation. Base plates for bolted installations are available upon request. Provide bolting arrangement with placement of order. Dimensions may vary depending on the actual O.D. and load requirements. PTFE slide bearings are recommended. See page 74 for sizes 20" – 36". See General Notes, pages 5 and 6.

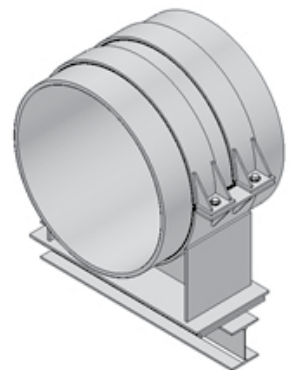

Pipe Size [in]	C [in]	L1 [in]	L2 [in]	W [in]	Allowable Loads [lb]
					Vertical
42	3	10	8	43	3750
48	3	12	10	49 1/4	4750
54	3	16	12	53 3/4	6000
60	3	16	12	59 1/4	7500

Pipe Supports

Figure D6: Duct Base Guide
(20"-36" Diameter)

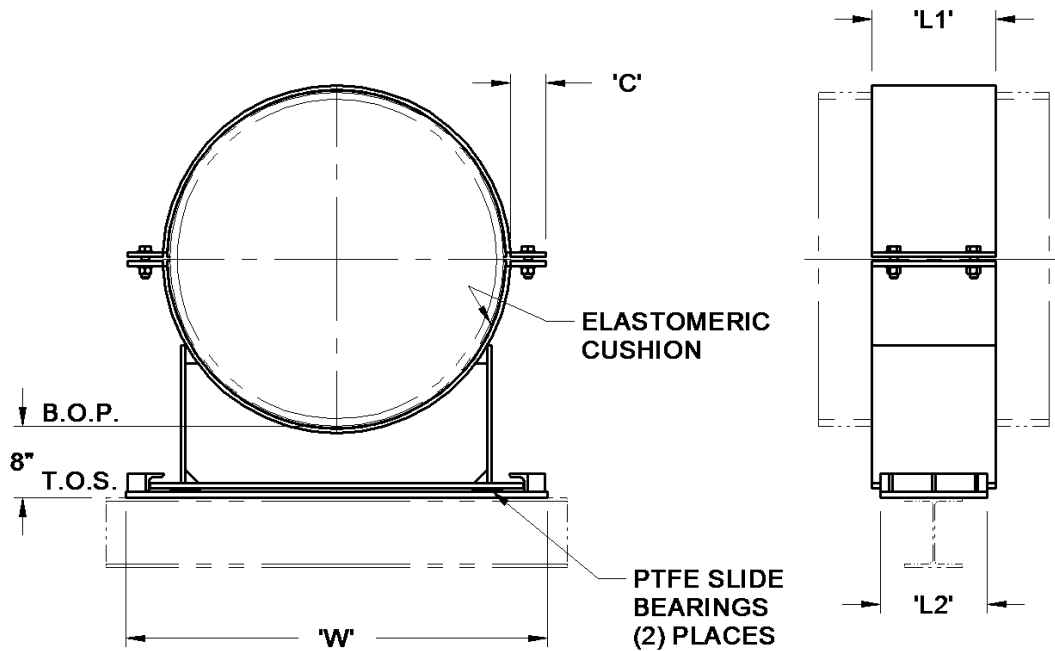

Finish:
20" – 30": Hot-dipped galvanized
36": Painted
See General Note 15, page 5.

Service:
To support weight of duct while allowing freedom of axial movement and limiting lateral movement

Material:
Carbon steel
See General Note 14, page 5.

Notes:
Support is provided with a base plate for welded installation. Base plates for bolted installations are available upon request. Provide bolting arrangement with placement of order. Dimensions may vary depending on the actual O.D. and load requirements. PTFE slide bearings are recommended. See page 77 for sizes 42" – 60". See General Notes, pages 5 and 6.

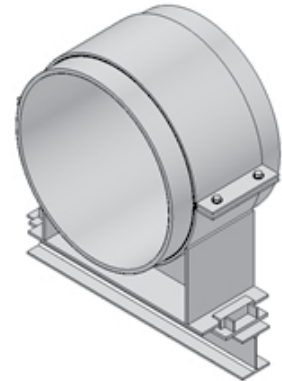

Pipe Size [in]	C [in]	L1 [in]	L2 [in]	W [in]	Allowable Loads [lb]	
					Lateral	Vertical
20	2 1/2	6	6	28	1800	900
24	2 1/2	6	6	33	2100	1200
30	2 1/2	8	6	38	3000	1750
36	2 1/2	10	8	43	4200	2400

Pipe Supports

Figure D6: Duct Base Guide

(42"-60" Diameter)

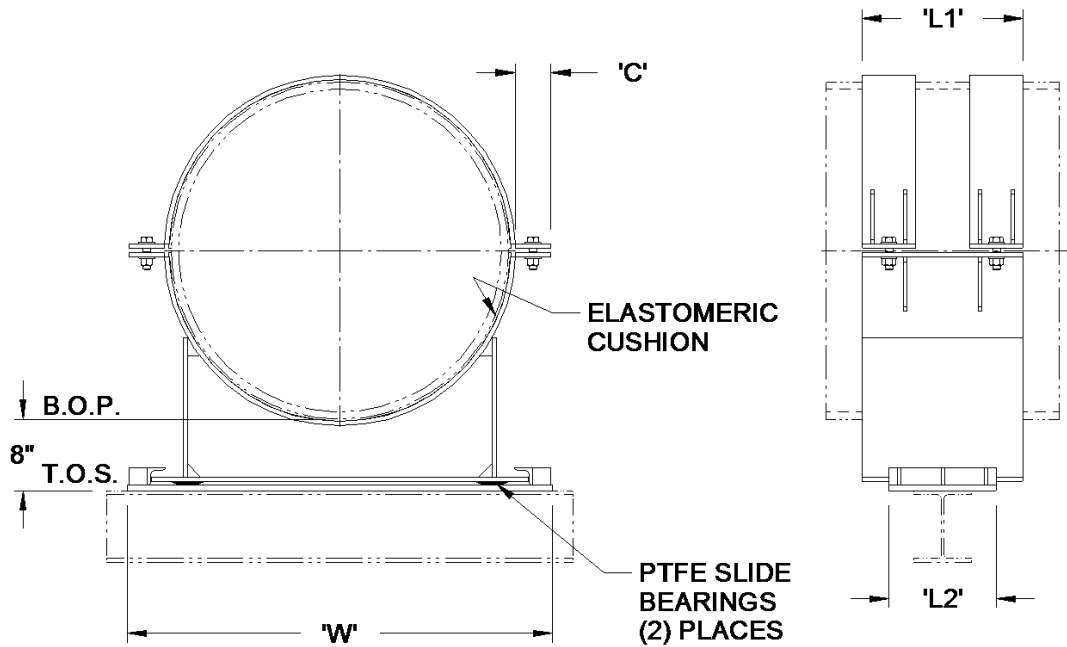

Finish:

Painted

See General Note 15, page 5.

Service:

To support weight of duct while allowing freedom of axial movement and limiting lateral movement

Material:

Carbon steel

See General Note 14, page 5.

Notes:

Support is provided with a base plate for welded installation. Base plates for bolted installations are available upon request. Provide bolting arrangement with placement of order. Dimensions may vary depending on the actual O.D. and load requirements. PTFE slide bearings are recommended. See page 76 for sizes 20" – 36". See General Notes, pages 5 and 6.

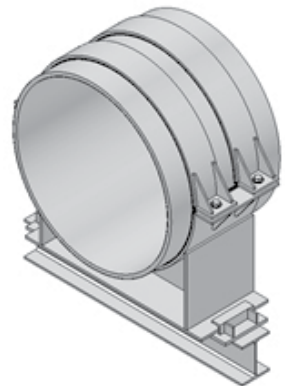

Pipe Size [in]	C [in]	L1 [in]	L2 [in]	W [in]	Allowable Loads [lb]	
					Lateral	Vertical
42	3	10	8	49 1/2	6000	3750
48	3	12	10	56	7500	4750
54	3	16	12	62	9000	6000
60	3	16	12	67 1/2	12000	7500

Pipe Supports

Figure D7: Duct Base Anchor
(20"-36" Diameter)

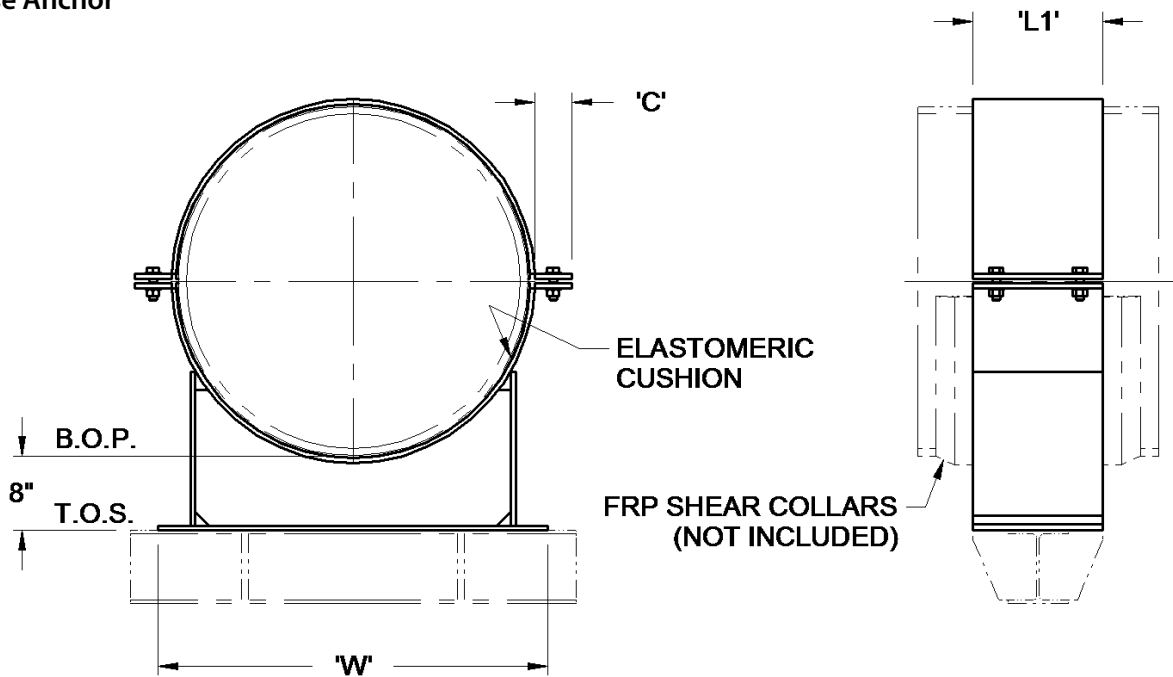

Finish:
20" – 30": Hot-dipped galvanized
36": Painted
See General Note 15, page 5.

Service:
To support weight of duct while restricting all movement

Material:
Carbon steel
See General Note 14, page 5.

Notes:
Base width (W) and length (L1) must be fully supported as shown. Support is provided with a base plate for welded installation. Base plates for bolted installations are available upon request. Provide bolting arrangement with placement of order. Dimensions may vary depending on the actual O.D. and load requirements. See page 79 for sizes 42" – 60". See General Notes, pages 5 and 6.

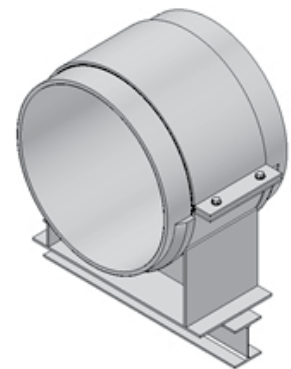

Pipe Size [in]	C [in]	L1 [in]	W [in]	Allowable Loads [lb]		
				Lateral	Vertical	Axial
20	2 1/2	8	24	1800	900	1800
24	2 1/2	8	27 3/8	2100	1200	2100
30	2 1/2	10	31 3/4	3000	1750	3000
36	2 1/2	12	36	4200	2400	4200

Pipe Supports

Figure D7: Duct Base Anchor
(42"-60" Diameter)

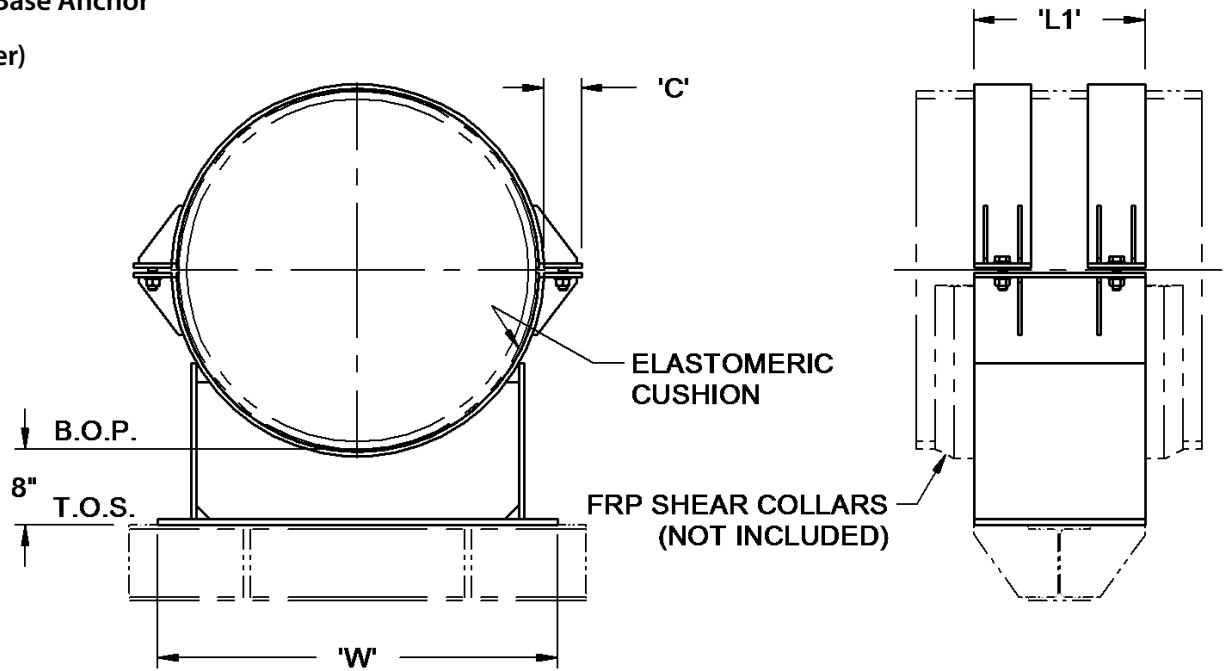

Finish:

Painted

See General Note 15, page 5.

Service:

To support weight of duct while restricting all movement

Material:

Carbon steel

See General Note 14, page 5.

Notes:

Base width (W) and length (L1) must be fully supported as shown. Support is provided with a base plate for welded installation. Base plates for bolted installations are available upon request. Provide bolting arrangement with placement of order. Dimensions may vary depending on the actual O.D. and load requirements. See page 78 for sizes 20" – 36". See General Notes, pages 5 and 6.

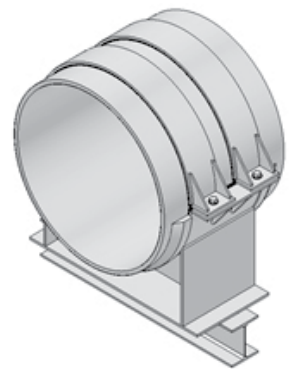

Pipe Size [in]	C [in]	L1 [in]	W [in]	Allowable Loads [lb]		
				Lateral	Vertical	Axial
42	3	14	43	6000	3750	6000
48	3	16	49 1/4	7500	4750	7500
54	3	18	53 3/4	9000	6000	9000
60	3	20	59 1/4	12000	7500	12000

Pipe Supports

Figure D16: Duct Riser Guide
(20"-30" Diameter)

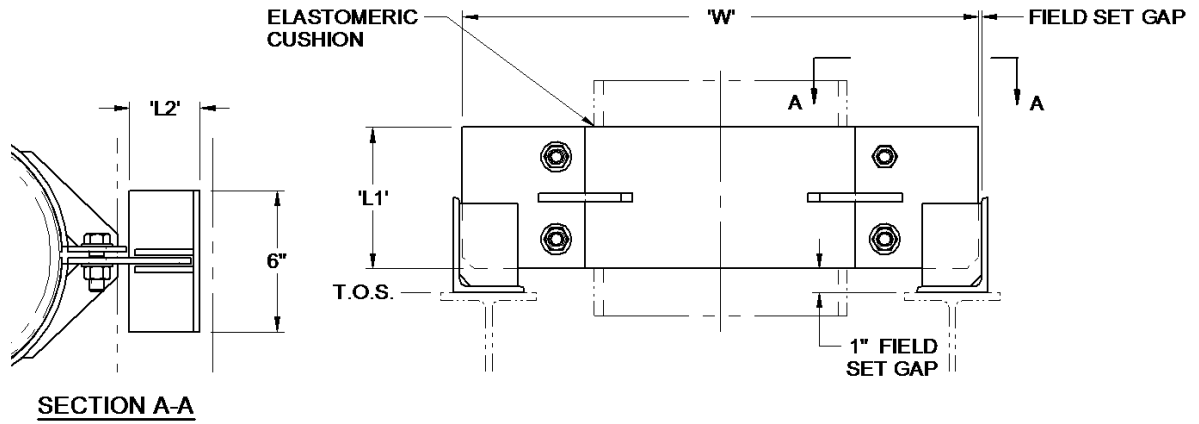

Finish:
Hot-dipped galvanized
See General Note 15, page 5.

Service:
To allow axial movement while limiting lateral movement

Material:
Carbon steel
See General Note 14, page 5.

Notes:
Not designed for vertical loads. Type RGC1 welded riser guide clips are provided with this style of support. Type RGC2 bolted riser guide clips are available upon request, page 87. Dimensions may vary depending on the actual O.D. and load requirements. See page 81 for sizes 36" – 60". See General Notes, page 5 and 6.

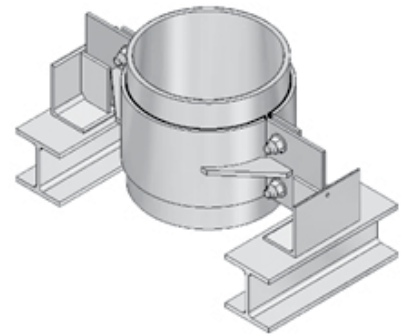

Pipe Size [in]	C [in]	L1 [in]	W [in]	Allowable Loads [lb]
				Lateral
20	6	4	34	1800
24	6	4	38	2100
30	8	4	44 1/2	3000

Pipe Supports

Figure D16: Duct Riser Guide
(36"-60" Diameter)

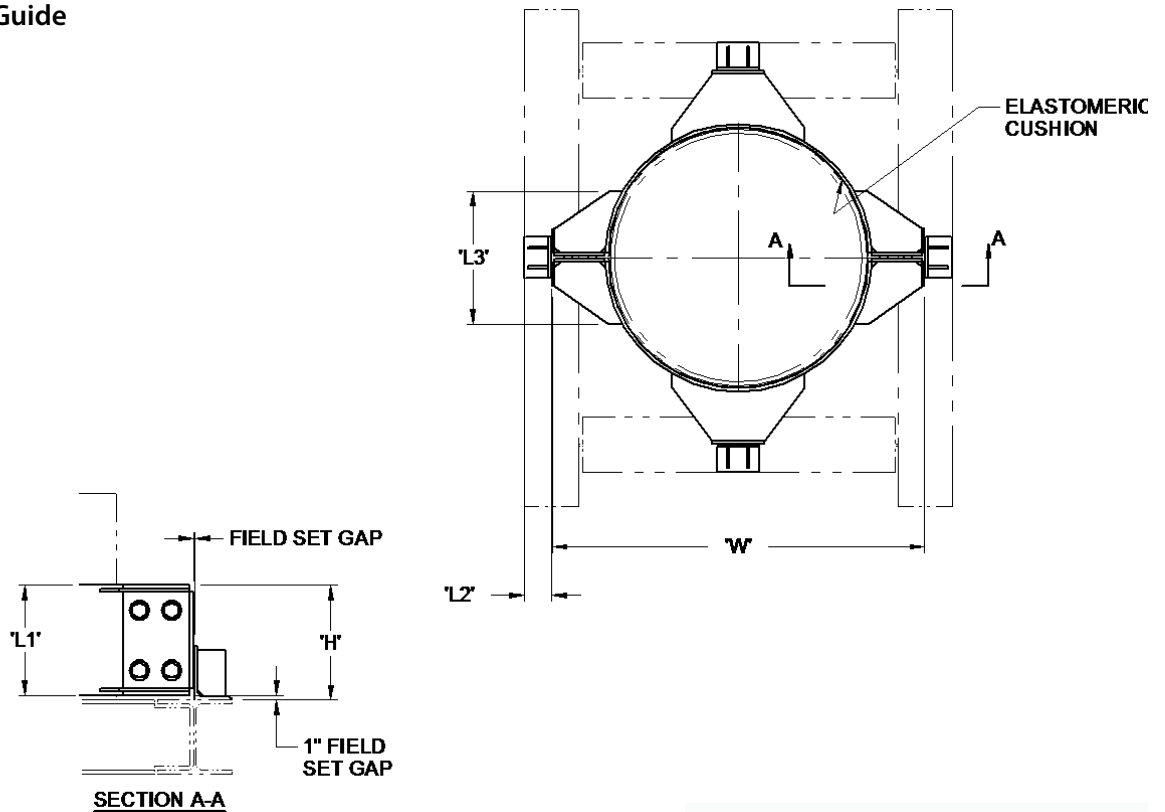

Finish:
Painted
See General Note 15, page 5.

Service:
To allow axial movement while limiting lateral movement

Material:
Carbon steel
See General Note 14, page 5.

Notes:
Not designed for vertical loads. Support width (W) is based on listed allowable loads. For a greater width, the support configuration may need to be adjusted to suit listed allowable loads. Type RGC1 welded guide clips are provided with this style support. Type RGC2 bolted riser guide clips are available upon request, page 87. Dimensions may vary depending on the actual duct O.D. and load requirements. See page 80 for sizes 20" – 30". See General Notes, pages 5 and 6.

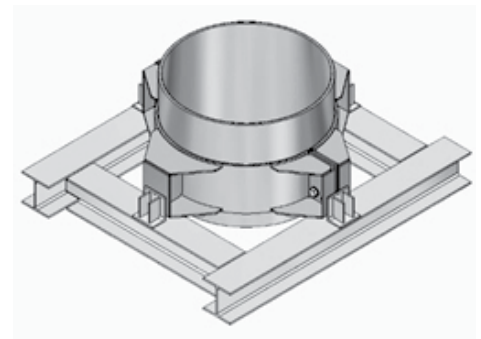

Pipe Size [in]	L1 [in]	L2 [in]	L3 [in]	W [in]	Allowable Loads [lb]
					Lateral
36	10	4	8	48	4200
42	10	4	10	56	6000
48	12	6	10	64	7500
54	16	6	12	70	9000
60	16	6	12	72	12000

Pipe Supports

Figure D17: Duct Riser Support W/ Guides
(20"-30" Diameter)

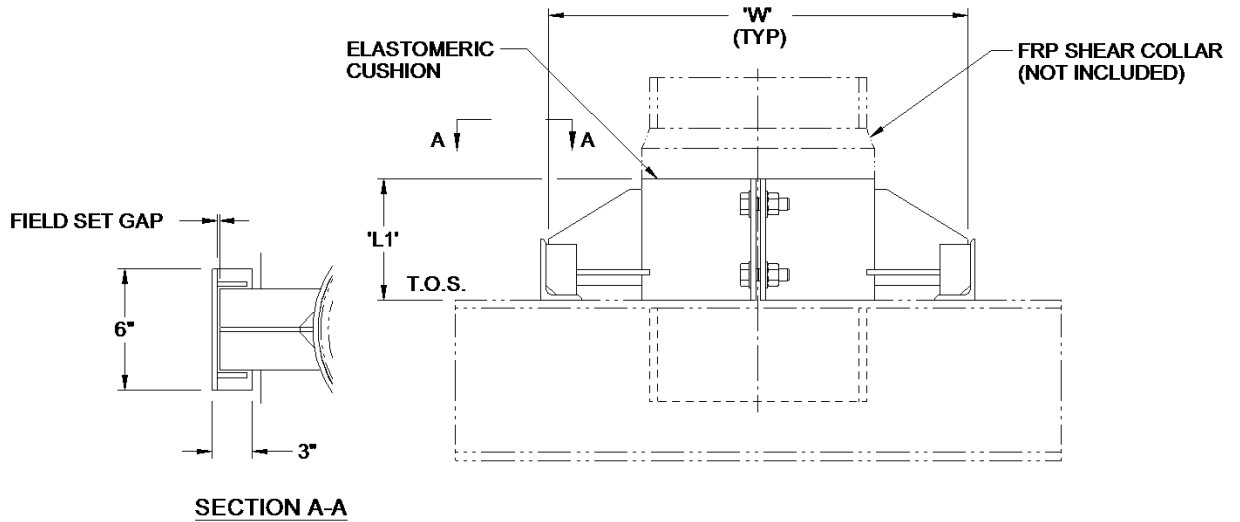

Finish:
Hot-dipped galvanized
See General Note 15, page 5.

Service:
To support weight of pipe or duct while limiting lateral movement

Material:
Carbon steel
See General Note 14, page 5.

Notes:
Support width (W) is based on listed allowable loads. For a greater width, the support configuration may need to be adjusted to suit listed allowable loads. Type RGC1 welded guide clips are provided with this style support. Type RGC2 bolted guide clips are available upon request, page 87. Dimensions may vary depending on the actual O.D. and load requirements. See page 83 for sizes 36" – 60". See General Notes, pages 5 and 6.

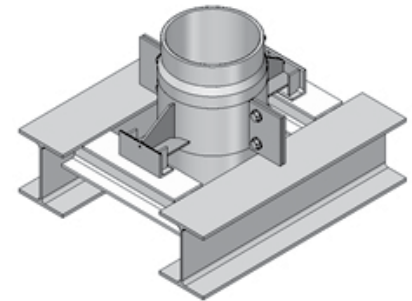

Pipe Size [in]	L1 [in]	W [in]	Allowable Loads [lb]	
			Lateral	Vertical
20	8	34	1800	900
24	8	38	2100	1200
30	10	44 1/2	3000	1750

Pipe Supports

Figure D17: Duct Riser Support W/ Guides

(36"-60" Diameter)

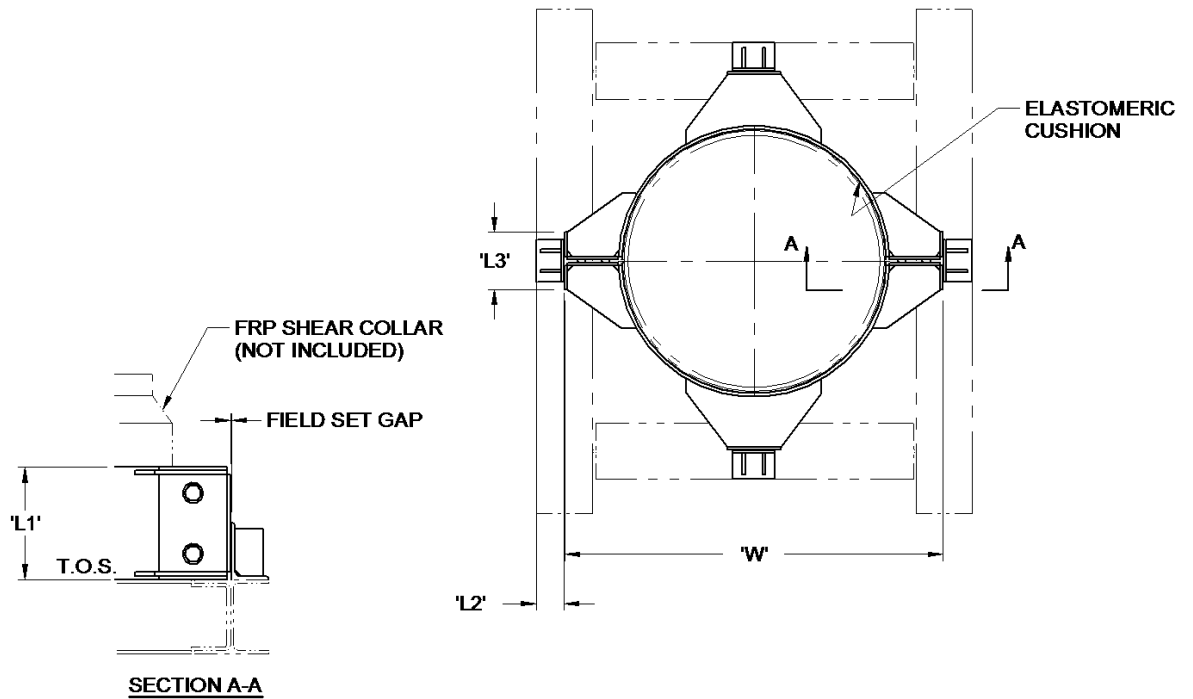

Finish:

Painted

See General Note 15, page 5.

Service:

To support weight of duct while limiting lateral movement

Material:

Carbon steel

See General Note 14, page 5.

Notes:

Support width (W) is based on listed allowable loads. For a greater width, the support configuration may need to be adjusted to suit listed allowable loads. Type RCG1 welded riser guide clips are provided with this style support. Type RCG2 bolted riser guide clips are available upon request, page 87. Dimensions may vary depending on the actual duct O.D. and load requirements. See page 82 for sizes 20" – 30". See General Notes, pages 5 and 6.

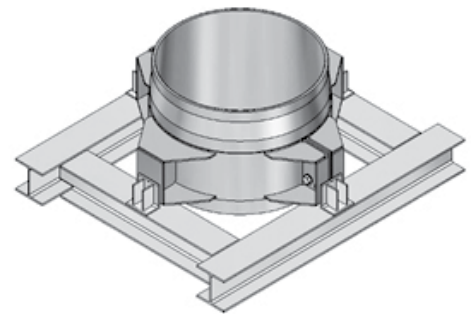

Pipe Size [in]	L1 [in]	L2 [in]	L3 [in]	W [in]	Allowable Loads [lb]	
					Lateral	Vertical
36	12	4	8	48	4200	2400
42	14	4	10	56	6000	3750
48	16	6	10	64	7500	4750
54	18	6	12	70	9000	6000
60	20	6	12	72	12000	7500

Support Options

Figure O1: Variable Spring Hanger Supports

Variable spring hanger supports are used at locations that are subjected to vertical thermal displacements. The size and type of variable spring hangers to be used depends on the load requirements and the method of installation. The actual load for which the spring is to support (hot condition), and the amount and direction of the pipe line movement from the cold to the hot position is required to properly determine sizes.

This illustration above depicts a large diameter base mount type support with slide bearings and variable spring hangers. Other configurations are available such as single and / or double rod type suspended from above.

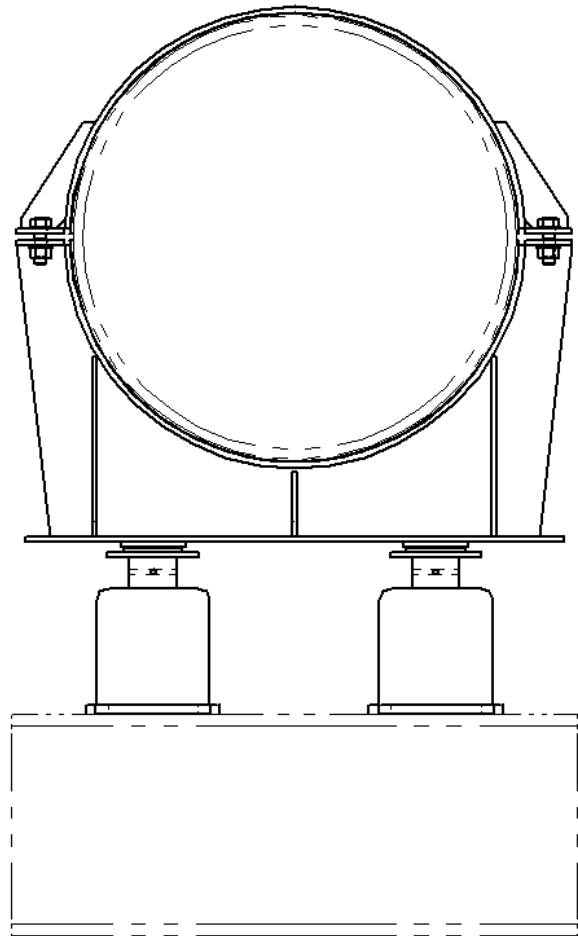

BASE MOUNTED DOUBLE CAN

Figure O2: Slide Bearings

Slide bearings minimize the frictional resistance of pipe supports as much as 40% thus reducing the chance of the pipe supports binding and creating localized stresses in the pipe. Slide bearings also reduce the loads transferred to a supporting structure. As pipe sizes and dead weights increase, slide bearings become more critical with the increased frictional loads. Slide bearings are recommended for all pipe sizes 12" diameter and above and systems having large temperature gradients and displacements.

PTFE slide bearings are bonded to steel backing plates, which are then welded to upper and lower support base plates. For pipe supports without a lower base plate, the lower bearing can be welded directly to the supporting structure.

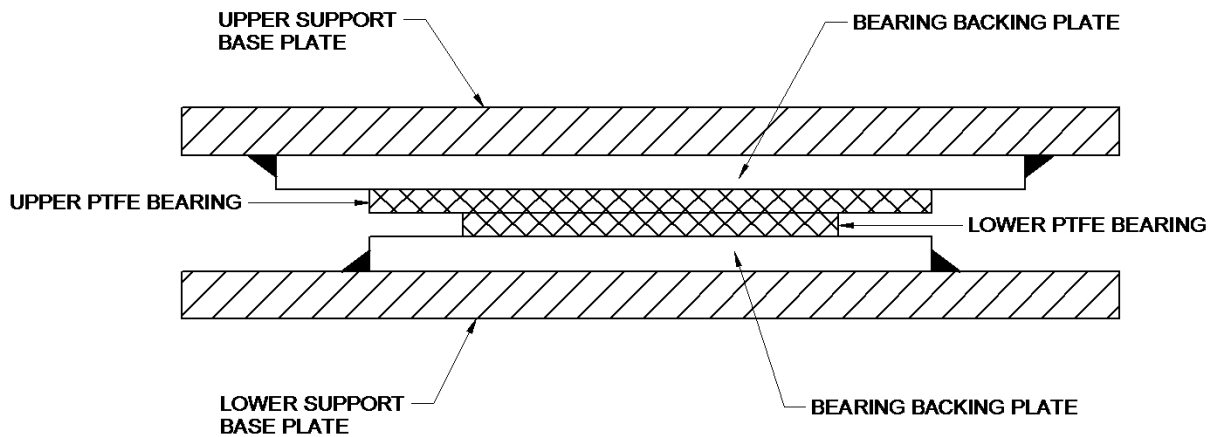

Pipe Supports

Figure O3: Base Plates

If base plates are desired to accompany pipe supports, base plates may be supplied as part of a total assembly. Base plates are available in standard dimensions or to customer specifications. The standard base plate provided with our base mounted supports is for welded installations. All base mounted supports with slide bearings are provided with both an upper and a lower base plate that includes the slide bearing assemblies. Base plates can be provided for bolted

installations upon request. Please provide bolting configuration requirements with placement of order.

Note:
The type of guide and linestop clips depends on the style of the support and may vary from what is indicated here.

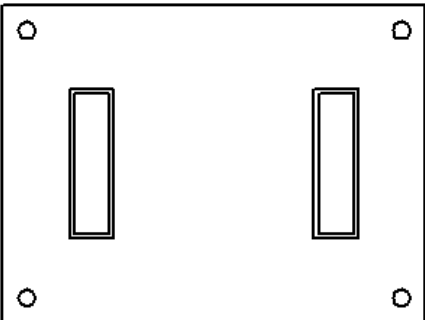

BP1
Slide Baseplate

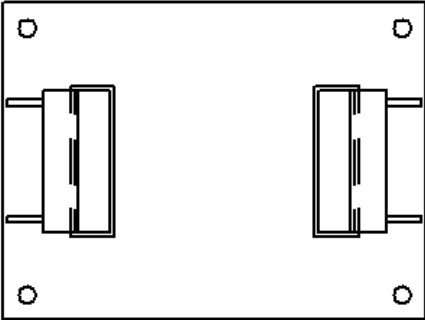

BP2
Guide Baseplate
(See Note)

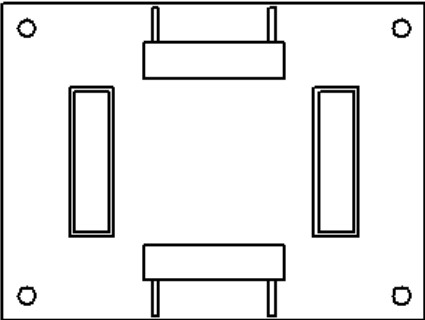

BP3
Linestop Baseplate
(See Note)

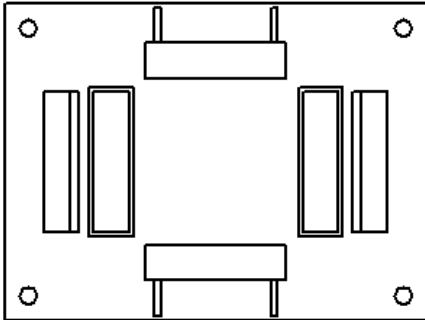

BP4
Linestop Baseplate W/
Lateral Limits
(See Note)

Figure O4: Guide Clips

Type FB1 is designed to limit horizontal (lateral or axial depending on placement) and vertical displacements. It is provided with our standard supports without slide bearings or lower base plates. It is designed for field welded installations.

Type FB2 is designed to limit horizontal (lateral or axial depending on placement) and vertical displacements. It is for use with our standard supports without slide bearings and lower base plates.

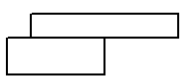
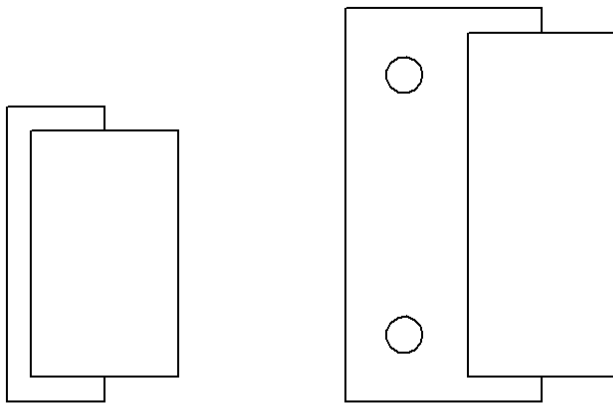

TYPE FB1

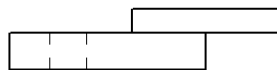

TYPE FB2

Type RGC1 is designed to limit horizontal displacements of riser piping. It is provided with our riser supports and is shipped loose for field welded installations.

Type RGC2 is designed to limit horizontal displacements of riser piping. It is designed for bolted installations and can be provided in lieu of the standard Type RGC1 upon request.

Types GC1 is designed to limit horizontal (lateral or axial depending on placement) and vertical displacements. It is provided with our standard supports with slide bearings and is factory welded to the lower base plate. Upon request, it can be provided loose for field installation. The standard lower base plate can also be re-sized to allow for installation direct to the supporting structure.

Type GC2 is designed to limit only lateral and axial displacements and can be used with or without slide bearing or lower base plates. It allows for either field welded or bolted installations.

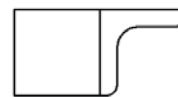
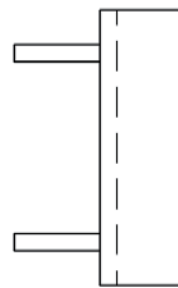

TYPE GC1

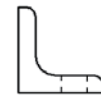
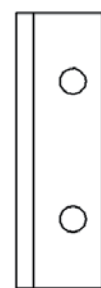

TYPE GC2

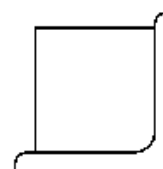
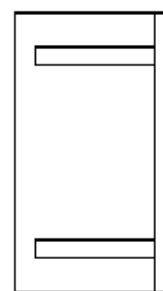

TYPE RGC1

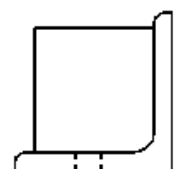
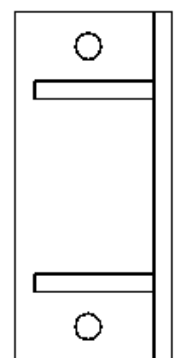

TYPE RGC2

Pipe Supports

Figure O5: Expansion Joint W/ Control Rods

The purpose of an expansion joint is to absorb the expansion and contraction of a pipeline between two anchoring points. A Control Unit Assembly is a system of tie rods placed across an expansion joint to minimize expansion and contraction thereby eliminating possible damage to the expansion joint. Control Unit Assemblies are also used when it is not feasible in the supporting structure to provide an anchoring system to control the expansion and contraction of the piping system.

An expansion joint Control Unit Assembly for an FRP piping system usually consists of sectional backing plates (360° coverage) to distribute the imposed loads around the pipe flanges, tie-rod lugs, tie-rods and compression sleeves. The number of tie-rods used in an assembly is determined on the basis of the actual design/test pressure of the system. Pipe flange strength must be considered to insure they are sufficient to withstand the total force that will be imposed.

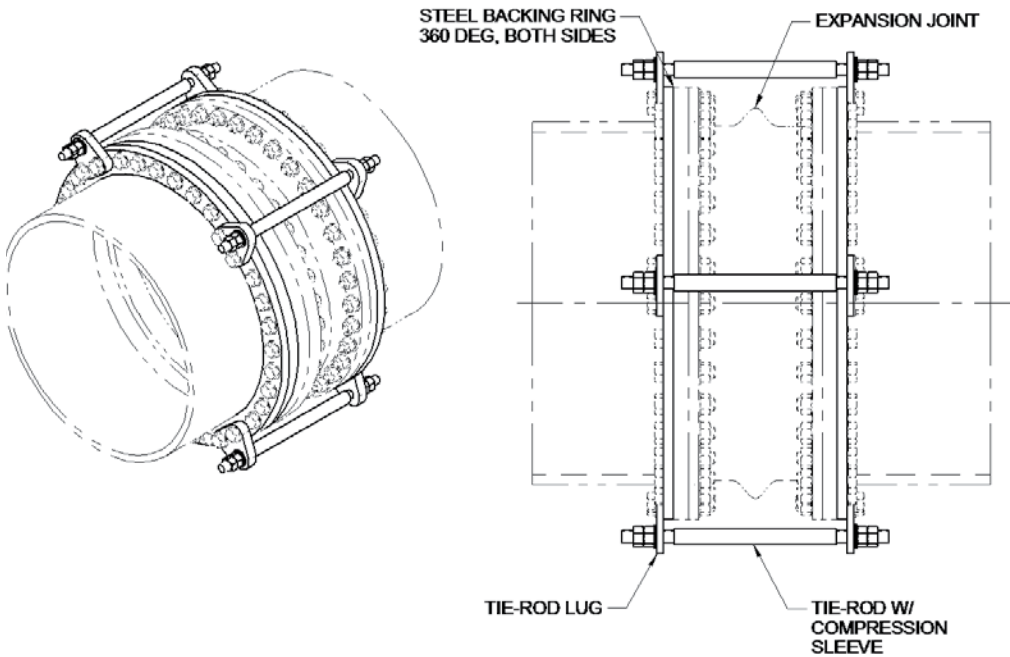

Painting Specification

1.0 GENERAL

1.1. Scope

1.1.1. This specification covers the general requirements for cleaning, surface preparation and painting of steel structures and equipment.

1.2. References

1.2.1. Coatings and their application shall comply with the latest revision of the following referenced publications unless otherwise specified.

SSPC Steel Structures Painting Council

1.3. Painting Requirements

1.3.1. All coating materials shall be the product of a single manufacturer. Not substitutions or additives from different manufacturers are allowed without approval by the Owner.

1.3.2. If pipe support rubber lining if installed, remove and re-apply after painting is completed.

1.3.3. Remove all fasteners and other threaded hardware prior to blasting and painting.

1.3.4. Protect all non-metallic surfaces such as PTFE slide bearings during blasting and painting operations.

1.3.5. Galvanized surfaces shall be prepared with Carboline Rust Bond and painted with the appropriate paint system requirements.

2.0 PAINT MATERIALS

2.1. Paint System Selection

2.1.1. This section is applicable to the painting of non-insulated surfaces for steel fabricated equipment.

2.1.2. The following paint systems service and usage are described as follows:

Paint System	Service	Usage
Type 1	Severe corrosive service	Material located in a highly acidic environments and exposed to splashes, spills and outdoor conditions
Type 2	Moderate corrosive service	Material located in a mild to moderate acidic environments and exposed to outdoor conditions
Type 3	Mild to non-corrosive service	Material located in a mild to non-corrosive environments and not exposed to outdoor conditions

3.0 PAINTING SPECIFICATION

3.1. Paint

3.1.1. Paint systems consist of the following primer and finish paints:

Paint System	Type 1	Type 2	Type 3
Primer	Carboline	Carbomastic 615HS	Not Required
Finish	Carboline Carboguard 890	Carboline Carboguard 890	Caroline Carboguard 890

3.1.2. Colors shall be determined by Owner.

4.0 EXECUTION

4.1. Cleaning of Surfaces

4.1.1. Prior to blasting, all surfaces shall be thoroughly cleaned of oil, grease and other contaminants by solvent washer per SSPC-SP 1.

4.1.2. Weld splatter and mill scale shall be removed by mechanical means in accordance with SSPC-SP2, Hand Tool Cleaning or SP3, Power tool cleaning.

4.1.3. Metal surfaces shall be abrasive cleaned in accordance with the SSPC-SP6, Commercial Blast Cleaning.

Pipe Supports

4.2. Surface Conditions Prior to Painting

- 4.2.1. Surfaces after blasting shall be cleaned by vacuum or blown off with compressed air that is free of oil and water. All surfaces must be cleaned and dried.
- 4.2.2. Surface temperature must not be 5°F (2°C) colder than ambient temperature. Surface temperature must be at least 40°F minimum to 110°F maximum when relative humidity is above 85% or when the surface or air temperature is within 5°F of the dew point.
- 4.2.3. For sandblasted surfaces, the anchoring pattern must be 1.5 to 3 mils deep.

4.3. Mixing and Thinning

- 4.3.1. All paints shall be thoroughly mixed prior to use (preferably with a mechanical mixer) in accordance with the paint manufacturer's instructions.
- 4.3.2. Paint shall be diluted only with products recommended by the paint manufacturer and in accordance with the paint manufacturer's instructions.
- 4.3.3. All additional ingredients shall be mixed in accordance with the paint manufacturer's mixing proportions and instructions.

4.4. Painting Application

- 4.4.1. Conform to SSPC-PA1 standards (shop, site and maintenance painting) and to painting manufacturer recommendations. Prime surfaces immediately after cleaning to avoid rust formation.
- 4.4.2. The primer shall be fully cured prior to the application of the finish coat.

4.5. Paint Thickness

4.5.1. Dry film thickness (DFT) must be as follows:

Paint System	Type 1	Type 2	Type 3
Primer	1.5 to 2.0 mils	1.5 to 2.0 mils	N/A
Finish	2.0 to 2.5 mils	2.0 to 2.5 mils	2.0 to 2.5 mils

4.6. Inspection

- 4.6.1. Supplier shall provide an inspection report for each painting operation. This report shall include:
 - 4.6.1.1. Wet film thickness measurements per coat
 - 4.6.1.2. Dry film measurements per coat in accordance with SSPC PA2, Method for Determining Dry Film Thickness of a dry film using magnetic gauge
- 4.6.2. Supplier shall submit inspection reports prior to shipping equipment.

5.0 FIELD TOUCH UP FOR SHOP APPLIED COATING SYSTEM

- 5.1. Where only finish coat damage has occurred; power tool clean and feather edges and recoat using the specified finish coating material.
- 5.2. Where coating is damaged with bare metal exposed; power tool clean and feather edge each coating layer and recoat using the specified finish starting with primer and then finish coat.

RPS Composites Inc.

740 Main Street

P.O. Box 299

Mahone Bay, Nova Scotia

Canada B0J 2E0

Tel: (902) 624.8383 | (800) 343.9355

Fax: (902) 624.6395

www.rpscomposites.com

